

PZ(III) 系列可编程智能电测表

PZ(III) series programmable intelligent meter

——单相表部分

Part of single phase meter

(AI、AV、E、DI、DV、F、PF)

安装使用说明书 V1.2

Installation and operation instructions V1.2

安科瑞电气股份有限公司

Acrel Co.,Ltd.

申 明

Declaration

版权所有，未经本公司之书面许可，此手册中任何段落，章节内容均不得被摘抄、拷贝或以任何形式复制、传播，否则一切后果由违者自负。

本公司保留一切法律权利。

All rights reserved. Without the written permission of the Company, no paragraph or section in this manual shall be copied, copied or disseminated in any form. Otherwise, all consequences shall be borne by the violator.

Our company reserves all legal rights.

本公司保留对手册所描述之产品规格进行修改的权利，恕不另行通知。
订货前，请垂询当地代理商以获悉本产品的新规格。

Our company reserves the right to modify the product specifications described in the manual without prior notice. Before placing an order, please consult your local agent for new specifications.

目 录

1 概述 Overview	1
2 产品型号规格 Product model and specification.....	1
3 技术参数 Technical parameters.....	2
4 安装指南 Installation guide.....	4
4.1 外形及安装开孔尺寸 Outline and installation cut-out size.....	4
4.2 仪表及开孔示意图 Meter and cut-out schematic diagram	4
4.3 安装示意图 Installation schematic diagram	4
4.4 安装说明 Installation instruction.....	5
4.5 端子及接线 Terminals and wiring.....	5
5 使用指南 Using guide.....	8
5.1 按键 Keys.....	8
5.2 菜单符号及意义 Menu symbol and meaning.....	9
5.3 编程流程(此流程以 LED 显示为例, LCD 显示与此类似)Programming process (this process takes LED display as an example, similar to LCD display).....	12
5.4 功能设置与使用 Function setting and usage.....	18
5.5 测量数据查看 Measurement data checking.....	21
6 通讯指南 Communication guide.....	23
6.1 概述 Overview.....	23
6.2 协议 Protocol.....	23
6.3 错误校验的方法 Error checking method.....	24
6.4 单相表通讯参量地址表 (Word) Single-phase Meter Communication Parameters Address Table (Word)	26
6.5 通讯应用 Communications applications.....	27

1 概述 Overview

PZ 系列单相表，采用交流采样技术，可直接或间接测量单相电网或三相电网中某一相的电能、功率、电压、电流和频率等。既可用于本地显示，又能与工控设备连接，组成测控系统。

PZ series single-phase meter, using AC sampling technology, can directly or indirectly measure the electric energy, power, voltage, current and frequency of a single phase or three phase power grid. It can not only be used for local display, but also can be connected with industrial control equipment to form a measurement and control system.

仪表可具有 RS-485 通讯接口，采用 Modbus-RTU 协议；可带模拟量输出、继电器报警输出、开关量输入/输出。根据不同要求，通过仪表面板按键，对变比、报警、通讯等参数进行设置和控制。

The meter have RS-485 communication port, using MODBUS-RTU protocol; Analog output, relay alarm output, switching input/output. According to different requirements, parameters such as variable ratio, alarm and communication can be set and controlled through the instrument panel keys.

2 产品型号规格 Product model and specification

仪表型号 Meter model	基本功能 Basic function	外形 Outline	可选功能 Optional functions
PZ48-AI PZ48-AV	单相电流、电压测量； LED 数码管显示 Measurement of single-phase current, voltage; LED display	48 方形 48 Square	1、一路 RS485 通讯 (/C) 1channel RS485 communication (/C) 2、一路变送输出 (/M) 1channel transmitting output(/M)
PZ48L-AI PZ48L-AV	单相电流、电压测量； LCD 液晶显示 Measurement of single-phase current, voltage; LCD display		
PZ72-AI PZ72-AV PZ72-E PZ72-F	单相电流、电压、电能、频率测量； LED 数码管显示 Measurement of single-phase current, voltage, energy and frequency; LED display	72 方形 72 Square	1、一路 RS485 通讯 (/C) 1channel RS485 communication (/C) 2、一路变送输出 (/M) 1channel transmitting output(/M) 3、一路报警 (/J) 1channel alarm (/J) 4、变送输出+RS485 通讯 (/MC) Transmitting output + RS485 communication (/MC) 5、RS485 通讯+开关量 2DI (/KC) RS485 communication+Switching 2DI (/KC) 6、RS485 通讯+开关量 2DI2DO (/KC) RS485 communication+Switching 2DI2DO (/KC) 7、一路报警+一路变送输出+RS485 通讯 (/JMC) 1channel alarm+1channel transmitting output+RS485 communication (/JMC)
PZ72-DI PZ72-DV	直流电流、电压测量； LED 数码管显示 Measurement of DC current, voltage; LED display		
PZ72L-AI PZ72L-AV PZ72L-E PZ72L-F PZ72L-PF	单相电流、电压、电能、频率、功率因数测量； LCD 液晶显示 Measurement of single-phase current, voltage, energy, frequency and power factor; LCD display		
PZ72L-DI PZ72L-DV	直流电流、电压测量； LCD 液晶显示 Measurement of DC current, voltage; LCD display		

PZ96-AI PZ96-AV	单相电流、电压测量; LED 数码管显示 Measurement of single-phase current, voltage;LED display	96 方形 Square	1、一路 RS485 通讯 (/C) 1 channel RS485 communication (/C) 2、一路变送输出 (/M) 1channel transmitting output(/M) 3、一路报警 (/J) 1channel alarm (/J) 4、变送输出+RS485 通讯 (/MC) Transmitting output + RS485 communication (/MC) 5、RS485 通讯+开关量 4DI2DO (/KC) RS485 communication+Switching 4DI2DO (/KC) 6、一路报警+一路变送输出+RS485 通 讯 (/JMC) 1channel alarm+1channel analog output+RS485 communication (/JMC)
PZ96L-AI PZ96L-AV	单相电流、电压测量; LCD 液晶显示 Measurement of single-phase current, voltage;LCD display		
注: /J 为一 路继电器输出 (与第二路开关量输出复用), 如有特殊需求请咨询本公司。 Note: /J is 1 channel output of one circuit relay (and output of the second channel switch multiplexing), if you have special needs, please consult our company.			

3 技术参数 Technical Parameters

技术参数 Technical Parameters		指 标 Indicator	
输入 Input	标称值 Nominal value	交流 AC	电压: AC100V、220V、380V; 电流: AC1A、5A; Voltage: AC100V, 220V, 380V;Current: AC1A, 5A; 特殊规格可事先咨询 Special specifications may be consulted in advance
		直流 DC	电压: 1000V、300V; 电流: 75mV、10V、0-20mA、4-20mA、5A, 10A; Voltage: 1000V, 300V;Current: 75mV, 10V, 0-20mA, 4-20mA, 5A, 10A; 特殊规格可事先咨询 Special specifications may be consulted in advance
	过载 Overload	电压: 1.2 倍持续, 2 倍持续 1 秒; 电流: 1.2 倍持续, 10 倍持续 1 秒 Voltage: 1.2 times duration, 2 times duration for 1 second;Current: 1.2 times duration, 10 times duration for 1 second	
	频率 Frequency	45Hz~65Hz	
功耗 Energy consumption	各电压、电流输入回路功耗均小于 0.5VA The power consumption of each voltage and current input circuit is less than 0.5VA		
精度等级		频率 0.05Hz, 其他 0.5 级	

Accuracy		Frequency 0.05Hz, other class 0.5	
功能 Function	显示 Display	LED 或 LCD 显示 LED or LCD Display	
	通讯 Communication	RS485, Modbus-RTU 协议 RS485, Modbus-RTU protocol	
	报警 Alarm	1 路继电器输出, 交流表容量: 1A/30VDC 或 1A/250VAC 1 way relay output, AC meter capacity: 1A/30VDC or 1A/250VAC	
	模拟量 Analog	DC4~20mA、DC0~20mA(负载 < 500Ω), DC0~5V(负载 > 1kΩ) 等 1 way DC4 ~ 20mA, DC0 ~ 20mA(load & LT;500 Ω), DC0 ~ 5 v (load & gt;1 k Ω), etc	
	脉冲 Pulse	输出方式: 1 路集电极开路的光耦脉冲 Output mode: 1 way optocoupler pulse with open collector	
		脉冲常数: 15000 imp/kWh Pulse constant: 15000 IMP /kWh	
开关量 Switch value	输入 Input	干接点输入, 内置电源, 光耦隔离 Dry contact input, built-in power supply, optocoupler isolation	
	输出 Output	2 路开关量输出, 常开继电器触点, 2 way switching output, normally open relay contact, 交流表容量: 1A/30VDC 或 1A/250VAC AC meter capacity: 1A/30VDC or 1A/250VAC 直流表容量: 2A/30VDC 或 2A/250VAC DC meter capacity: 2A/30VDC or 2A/250VAC	
电源 Power supply	电压范围 Voltage range	AC/DC 85-265V	
	功耗 Energy consumption	< 5VA	
绝缘电阻 Insulation resistance		$\geq 100M\Omega$	
工频耐压 Power frequency withstand voltage		电源端子组与信号输入、输出端子组之间2kV/1min (RMS) 2kV/1min (RMS) between power terminal set and signal input and output terminal set	
平均无故障工作时间 Mean trouble-free working time		$\geq 50000h$	
环境 Environment	温度 Temperature	工作: -10℃~+55℃ 贮存: -25℃~+70℃ Work: -10℃ ~ +55℃ Storage: -25℃ ~ +70℃	
	湿度	$\leq 93\%RH$, 不结露, 不含腐蚀性气体	

	Humidity	≤ 93%RH, no condensation, no corrosive gas
	海拔 Altitude	≤ 2500m

4 安装指南 Installation Guide

4.1 外形及安装开孔尺寸 Outline and installation cut-out size

仪表外形 Meter outline	面板尺寸 Panel size		壳体尺寸 Shell size			开孔尺寸 Cut-out size	
	宽 Width	高 Height	宽 Width	高 Height	深 Depth	宽 Width	高 Height
单位: mm Unit:mm							
48 方形 48 square	48	48	44	44	100	45	45
72 方形 72 square	75	75	66	66	98	67	67
96 方形 96 square	96	96	86	86	92	88	88

4.2 仪表及开孔示意图 Meter and cut-out schematic diagram

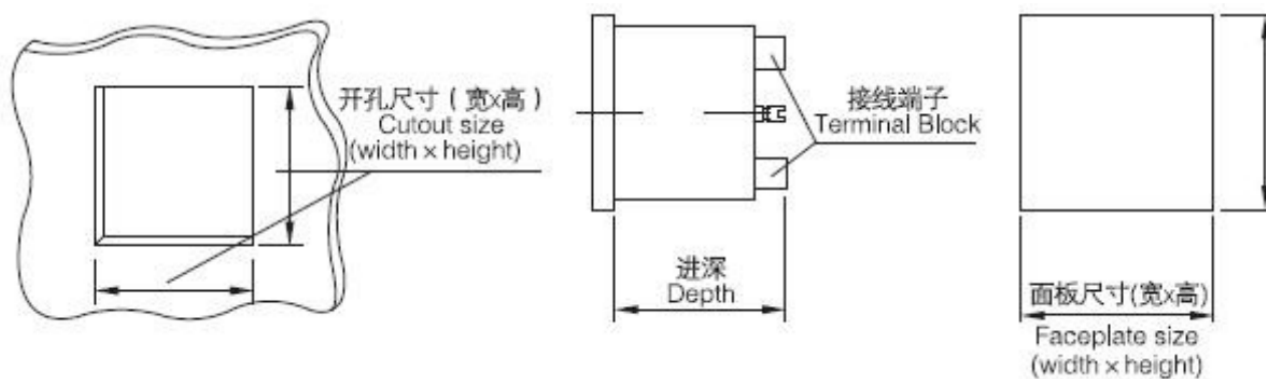

4.3 安装示意图 Installation schematic diagram

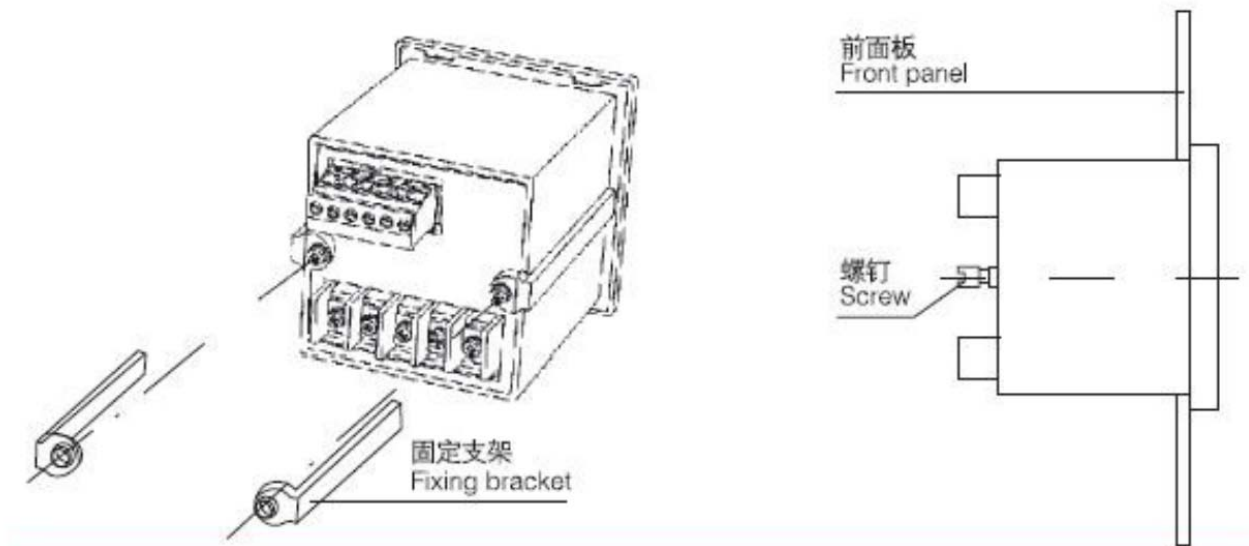

4.4 安装说明 Installation instruction

仪表安装时，松开固定支架锁紧螺钉，取下固定支架，将仪表嵌入安装孔内，装上固定支架，拧紧螺钉，使仪表安装牢固，不松动即可。48外形为卡簧片挤压安装。

When install the meter, loosen the locking screw of the fixing bracket, remove the fixing bracket, insert the instrument into the mounting hole, install the fixing bracket and tighten the screw to make the instrument be firmly installed without loosening. Shape for clamp reed squeeze installation.

4.5 端子及接线 Terminals and wiring

4.5.1 辅助电源与信号输入端子 Auxiliary power and signal input terminals

交流系列接线 AC series connection

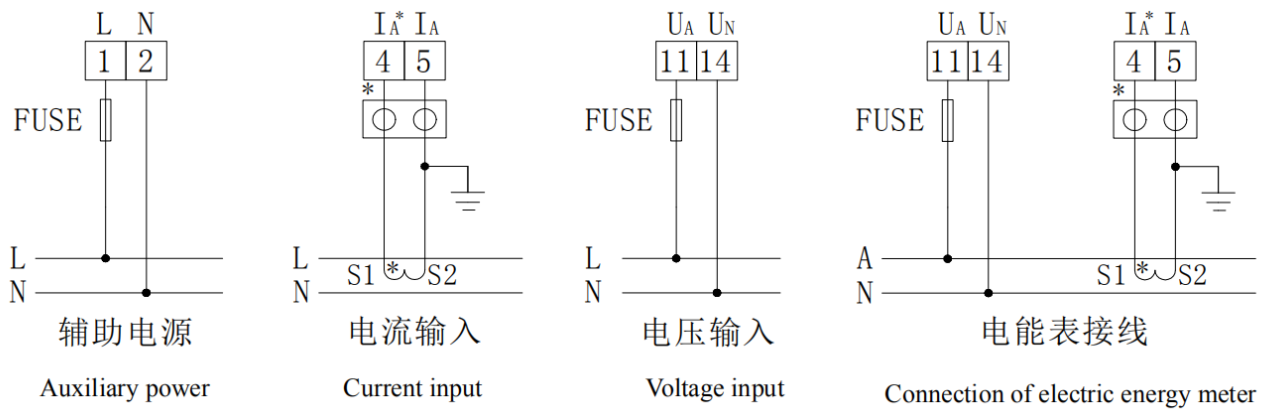

直流系列接线

DC series connection

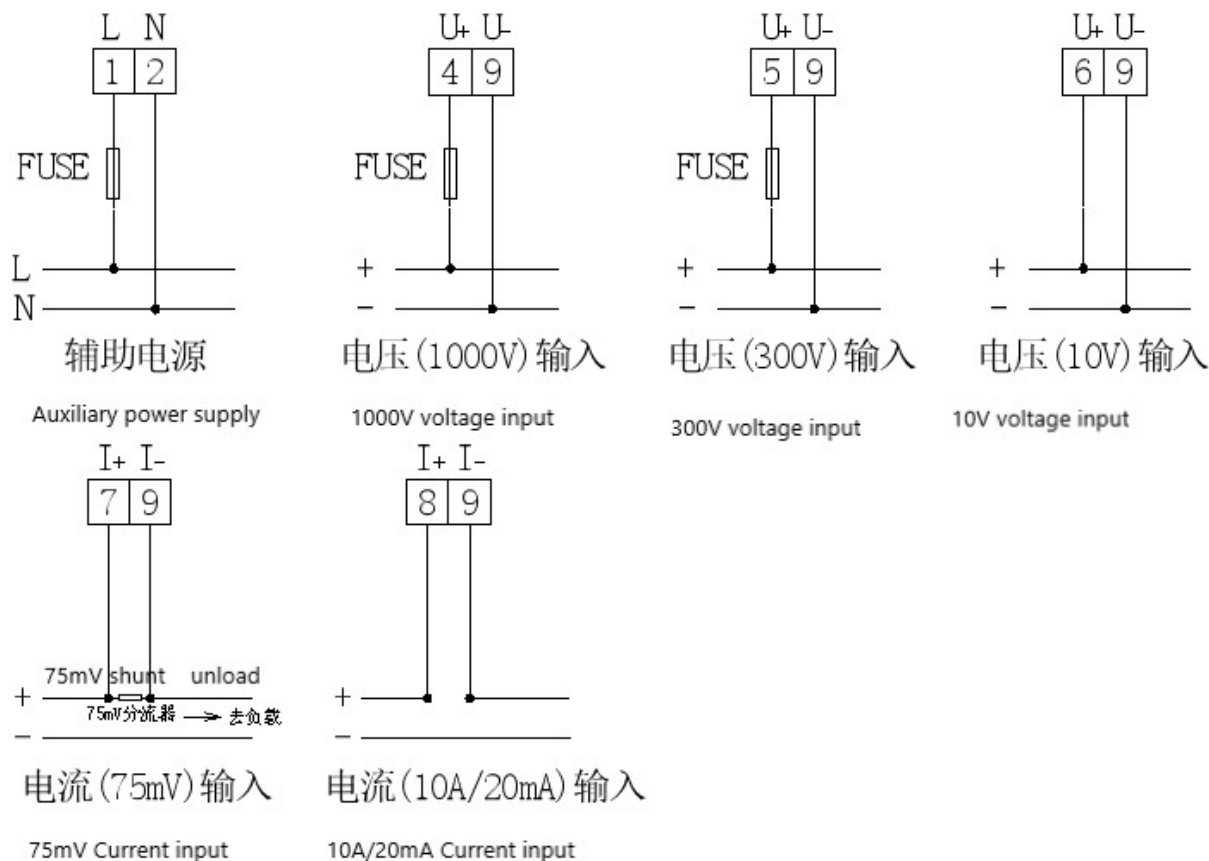

4.5.2 附加功能端子 Additional functional terminals

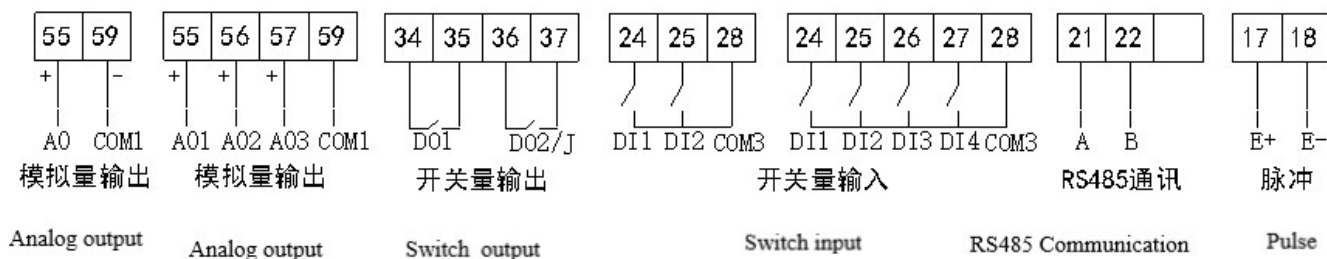

注: Note:

1. 符号“*”表示电流进线端, 该接线仅供参考, 具体以仪表上接线图为准;

The symbol "*" represents the end of the current inlet line. The connection is for reference only

2. 报警输出继电器与开关量输出 D02 复用。

Alarm output relay and switch output DO2 multiplexing.

4.6 注意事项 Matters needing attention

4.6.1 电压输入 Input voltage

输入电压不得高于产品额定输入电压的 120%, 否则应考虑使用 PT;

The input voltage shall not be higher than 120% of the rated input voltage of the product, otherwise PT shall be considered;

在电压输入端须安装 1A 保险丝。

1A fuse shall be installed at the voltage input end.

4.6.2 电流输入 Current input

交流电流输入应使用外部 CT;

External CT should be used for ac current input;

如果使用的 CT 上连有其它仪表，接线应采用串接方式;

If the CT used is connected with other instruments, the wiring should be in series;

建议使用接线排，不要直接接 CT，以便拆装;

It is recommended to use wiring bars, not directly connected to CT, so as to facilitate disassembly;

去除产品的电流输入连线之前，一定要先断开 CT 一次回路或短接二次回路;

Before removing the product's current input connection, the CT primary circuit or short secondary circuit must be disconnected first;

4.6.3 附加功能接线 Additional function connection

模拟量输出与开关量输入的 COM 表示各自公共端，并不是实际接地;

COM of analog output and switching input represents their common terminals, which are not actually grounded.

该仪表提供异步半双工 RS485 通讯接口，采用 MODBUS-RTU 协议，各种数据信息均可在通讯线路上传送。

理论上在一条线路上可以同时连接多达 128 个仪表，每个仪表均可设定其通讯地址 (Addr)，通讯速率 (baud) 也可通过设置选择。

The meter provides asynchronous semi-duplex RS485 communication interface and adopts modBUS-RTU protocol. All kinds of data and information can be transmitted on the communication line. Theoretically, up to 128 instruments can be connected on one line at the same time. Each instrument can set its address (Addr), and the communication rate (BAUD) can also be selected by setting.

通讯连接建议使用两芯屏蔽线，每芯截面不小于 0.5mm^2 ，分别接 A、B，屏蔽层接大地，布线时应使通讯线远离强电电缆或其他强电场环境。

It is recommended to use two shielded wires with A cross section of no less than 0.5mm^2 for communication connection. Connect A and B respectively. The shielding layer is connected to the ground.

关于通讯部分的接线实例如下图所示:

The wiring examples of the communication part are shown in the figure below

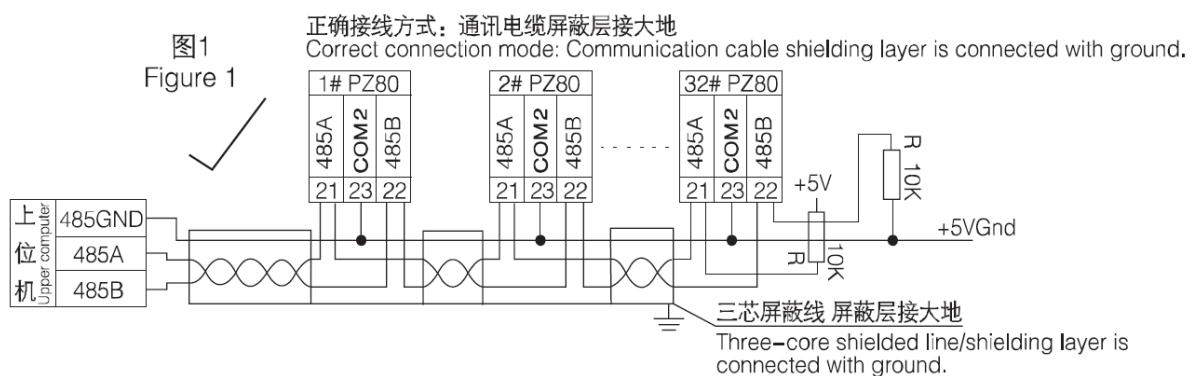

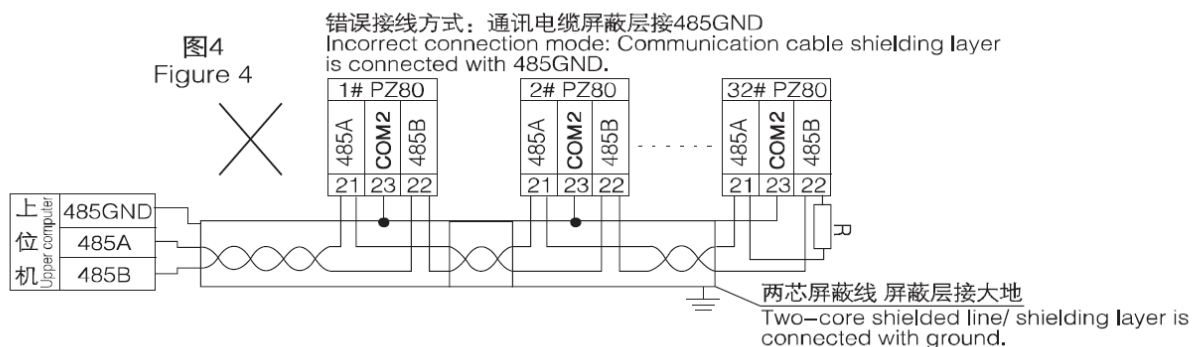
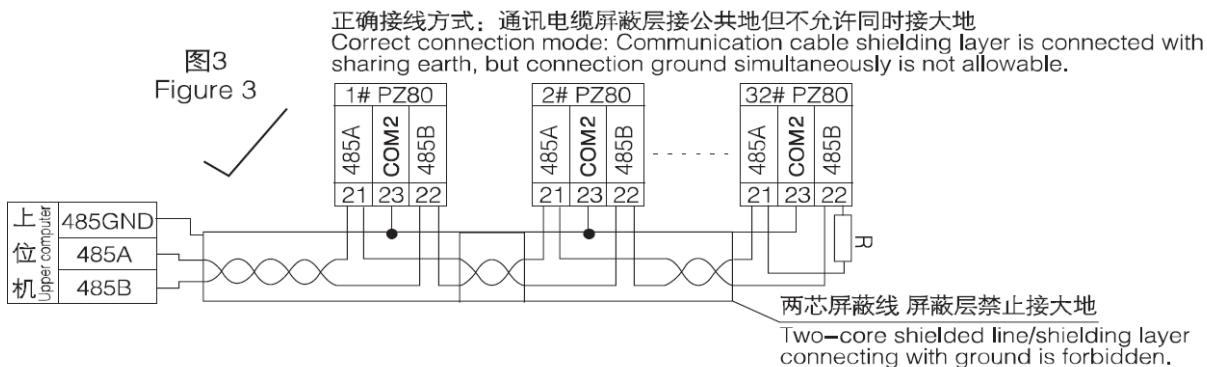
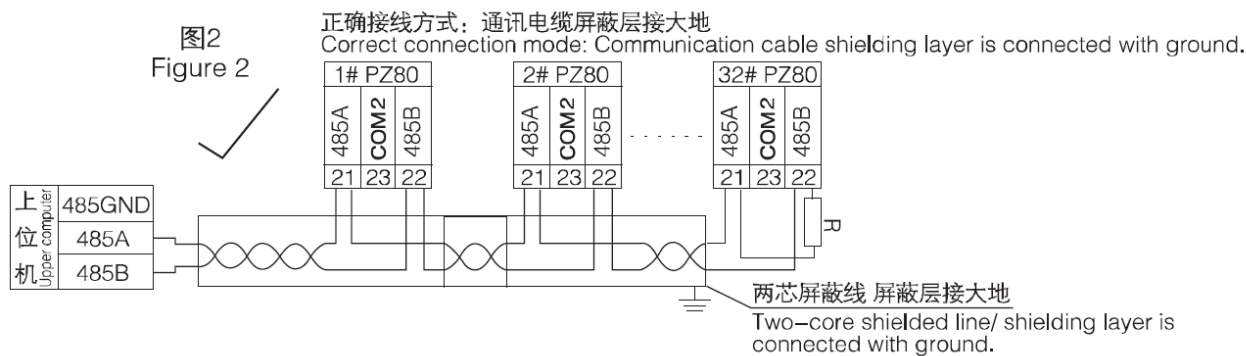

建议最末端仪表的 A、B 之间加匹配电阻，阻值范围为 $120\ \Omega \sim 10\text{k}\ \Omega$ 。

Suggest the meter at the end of the match resistance between A and B, value range is $120\ \Omega \sim 10\text{k}\ \Omega$.

5 使用指南 Using guide

5.1 按键 Keys



SET 键

SET Key



左移键

Left Shift Key



右移键

Right Shift Key



回车键

Enter Key

SET 键 —— 功能切换或返回上一级菜单；（正常显示、只读菜单与编程菜单之间切换）

SET key -- function switch or return to the previous menu;(Switch between normal display, read-only menu and programming menu)

左移键 —— 子菜单左移或减小数据；（电能表等正常状态下，按左右键，查看各项电量）

Left Shift Key-- Submenu moves or reduces data to the left;(Press left and right keys to check the electric quantity in normal state, such as electricity meter)

右移键 —— 子菜单右移或增大数据；（普通电流电压表等正常状态下，按住此键，查看报警信息）

Right shift key -- submenu moves right or increases data;(Press and hold this key to check the alarm information under normal current voltmeter)

回车键 —— 进入下一级菜单或确认；（正常状态，按此键，进入 DI/DO 指示与控制页面）

Enter key -- enter the next menu or confirm;(In normal state, press this key to enter the DI/DO instruction and control page)

5.2 菜单符号及意义 Menu symbol and meaning

5.2.1 PZ72 系列仪表 PZ72 series meters

类别 Type	符号 Symbol	含义 Meaning	范围 Range
主菜单 Main manu	rEAd	只读菜单 Read only menu	简写: rd Abbreviations: rd
	Prog	编程菜单 Programming menu	简写: Pg Abbreviations: Pg
变比 (倍率) Ratio (multiplier)	Pt (Ct)	电压 (电流) 变比 Voltage (current) ratio	0001~9999
直流表显示 设置 DC meter display Settings	H	满度显示 Full-scale display	-9999~9999
	L	零点显示 Zero check	-9999~9999
	A. P (U. P)	显示值小数点 Display value decimal point	0~3
	Z	零点屏蔽值 Zero shielding value	-9999~9999
	TYP	单位显示 unit display	A~Z 或者无 A~Z or none
通讯 Communicat ion	Add	通讯地址 Communication address	1~247
	C	通讯波特率 (bps) Communication baud rate (bps)	1.2、2.4、4.8、9.6 等 1.2、2.4、4.8、9.6 etc.
初始画面 Initial picture	Pg	上电显示的初始画面 initial screen of the power-on display	Page 的简写; 显示 U、A、P 等 Page abbr; Display U、A、P etc.
液晶背光 LCD backlight	LCD	背光延时时间 (s) Backlight delay time (S)	1-250, 0 为常亮, LED 仪表此项无效 1- 250,0 is always bright, LED meter is invalid
报警设置 Alarm setting	U. H	电压高报警设置 Voltage high alarm setting	0 ~150% (150%: 关闭) 0 ~ 150% (150% : off)
	U. L	电压低报警设置 Voltage low alarm setting	0 ~100% (0%: 关闭) 0 ~ 100% (0% : off)
	A. H	电流高报警设置 Current high alarm setting	0 ~150% (150%: 关闭) 0 ~ 150% (150% : off)
	A. L	电流低报警设置 Current low alarm setting	0 ~100% (0%: 关闭)

		Current low alarm setting	0 ~ 100% (0% : off)
	H. L	功率因数低报警设置 Power factor low alarm setting	0.000 ~ 1.000 (0.00 关闭) 0.000 ~ 1.000 (0.00 off)
	F. H	频率高报警设置 Frequency high alarm setting	9.99 ~ 99.99 (99.99 关闭) 9.99 ~ 99.99 (99.99 off)
	F. L	频率低报警设置 Frequency low alarm setting	9.99 ~ 99.99 (9.99 关闭) 9.99 ~ 99.99 (9.99 off)
	AL. b	回滞量设置 Hysteresis setting	0~99.9%
	AL. t	报警延时时间 (s) Alarm delay time (S)	1.0~20.0 (分辨率 0.1s) 1.0-20.0 (resolution: 0.1s)
继电器 (DO 输出) Relay (DO output)	do1. t	继电器 1 闭合持续时间 (s) Relay 1 Closing duration (S)	0~20 (分辨率 1s) 0 ~ 20 (resolution 1s)
	do2. t	继电器 2 闭合持续时间 (s) Relay 2 Closing duration (S)	0: 继电器工作在保持状态 0: The relay operates in the holding state
	do2. U	继电器 2 的用法 Relay 2 Use method	io: 作开关量 (K) ; AL: 作报警输出 (J) IO: Switching capacity (K);AL: Alarm output (J)
模拟量 Analog	o. L	模拟量下限设置 Set the lower limit of the analog quantity	0~100% (频率表除外) 0 ~ 100% (except frequency meter)
	o. H	模拟量上限设置 Set the upper limit of the analog quantity	0~120% (频率表除外) 0 ~ 120% (except frequency meter)
	o. U	模拟量输出选择 Analog output selection	U、A、P 等 U, A, P, etc
电能 Energy	CLr. E	电能清除 Energy clear	
	EP. EqE	电能显示 Energy Display	
量程 Measuring range	SP. U(A)	额定输入信号 Rated input signal	U: 电压 AC100V、220V、380V; (不可修改) A: 电流 AC1A、5A (不可修改) U: Voltage AC100V, 220V, 380V; (unmodifiable) A: Current AC1A, 5A (unmodifiable)
密码 Password	PS.	编程保护密码 Program-protected password	0000~9999
保存 Save	SAvE	询问是否保存 Ask whether to save	保存按“回车” Save and press “enter”

注：1. 普通 72 单相电流、电压中的报警菜单与上稍有不同，其不区分电流、电压信号，只表示数值的高低，为：AL.H（高报警）、AL.L（低报警）、AL.t（报警延时）；

Note: 1. The alarm menu of common 72 single-phase current and voltage is slightly different from the above. It does not distinguish current and voltage signals, but only represents the value, which is: AL.H (high alarm), AL.L (low alarm), and AL. T (alarm delay);

2. 各参数设置流程见 5.3.4 Prog 菜单；

2. See 5.3.4 Prog menu for each parameter setting process;

3. 百分数均相对于额定测量信号，频率、功率因数除外，报警值为一次值；

3. The percentages are relative to the rated measurement signals, except for frequency and power factor, and the alarm value is the primary value;

5.2.2 PZ48(96)系列仪表 PZ48(96) series meter

类别 Type	符号 Symbol	含义 Meaning	范围 Range
主菜单 Main menu	rEAd	只读菜单 Read only menu	
	Prog	编程菜单 Programming menu	
变比(倍率) Ratio (multiplier)	Pt (Ct)	电压(电流)变比 Voltage (current) ratio	0001-9999
通讯 Communication	Addr	通讯地址 Communication address	1~247
	bAUd	通讯波特率(kbps) Communication baud rate (kbps)	1.2、2.4、4.8、9.6等 1.2, 2.4, 4.8, 9.6, etc
液晶背光 Initial picture	LCd	背光延时时间(s) Backlight delay time (S)	1~250, 0为常亮, LED仪表此项无效 1- 250,0 is always bright, LED meter is invalid
报警设置 Alarm setting	AL. Hi	高报警设置 high alarm setting	0 ~150% (150%: 关闭) 0 ~ 150% (150% : off)
	AL. Lo	低报警设置 low alarm setting	0 ~100% (0%: 关闭) 0 ~ 100% (0% : off)
	AL. -t	报警延时时间(s) Alarm delay time (S)	1.0-20.0 (分辨率0.1s) 1.0-20.0 (resolution: 0.1s)
继电器 (DO 输出) Relay (DO output)	do1. t	继电器 1 闭合持续时间(s) Relay 1 Closing duration (S)	0-20 (分辨率 1s) 0: 继电器工作在保持状态 0-20 (resolution 1s) 0: The relay operates in the holding state
	do2. t	继电器 2 闭合持续时间(s) Relay 2 Closing duration (S)	
	do2. U	继电器 2 的用法 Relay 2 using method	io: 作开关量(K); AL: 作报警输出(J) IO: Switching capacity (K);AL: Alarm output (J)
模拟量 Analog	Ao. Lo	模拟量下限设置 Set the lower limit of the analog quantity	0~100% (频率表除外) 0 ~ 100% (except frequency meter)
	Ao. Hi	模拟量上限设置 Set the upper limit of the analog quantity	0~120% (频率表除外) 0 ~ 120% (except frequency meter)
量程 Measuring range	SP-U(A)	额定输入信号 Rated input signal	U 电压 AC100V、220V、380V A 电流 AC1A、5A (不可修改) U voltage AC100V, 220V, 380V A current AC1A, 5A (unmodifiable)
密码 Password	PASS	编程保护密码 Program-protected password	0000~9999
保存 Save	SAvE	询问是否保存 Ask whether to save	保存按“回车” Save and press “enter”

注：1. 各参数设置流程见 5.3.4 Prog 菜单；

Note: 1. See 5.3.4 Prog menu for each parameter setting process;

2. 百分数均相对于额定输入信号, 频率除外, 报警值为一次值；

The percentage is relative to the rated input signal, except the frequency, and the alarm value is the primary value;

5.3 编程流程（此流程以 LED 显示为例，LCD 显示与此类似）

Programming process (this process takes LED display as an example, and LCD display is similar)

5.3.1 PZ72 系列仪表在正常显示画面时，按 SET 键，如下：

When the PZ72 series meter displays the screen normally, press the SET key, as follows:

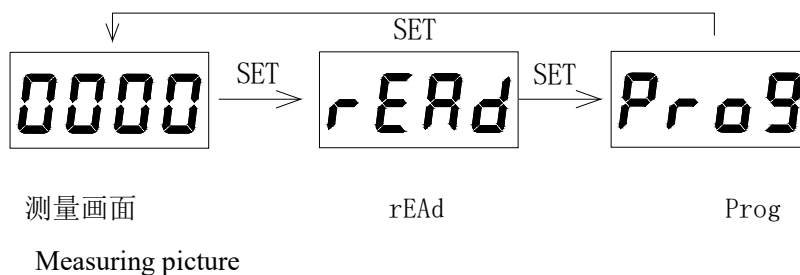

5.3.2 PZ48(96)系列仪表在测量画面时，按 SET 键，如下：

When PZ48(96) series meters measuring the screen, press the SET key, as follows:

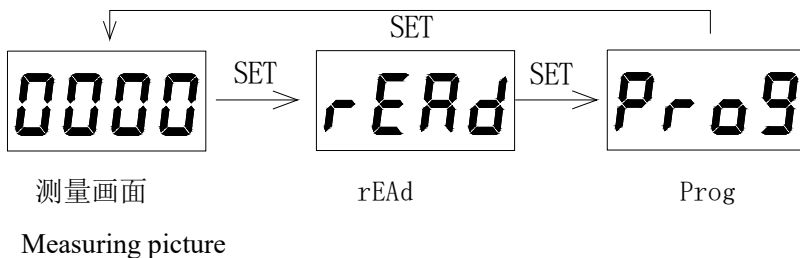

说明：Explanation

rEAd — 只读菜单，在此页面，按回车键进入；

rEAd - Read-only menu. On this page, press enter to enter.

Prog — 编程菜单，在此页面，按回车键进入；

Prog - Programming menu, on this page, press enter to enter;

5.3.3 rEAd 菜单（只读）

rEAd menu (rEAd only)

PZ72 系列单相电流表（PZ72-AI/*）：

PZ72 series single-phase ammeter(PZ72-AI/*)：

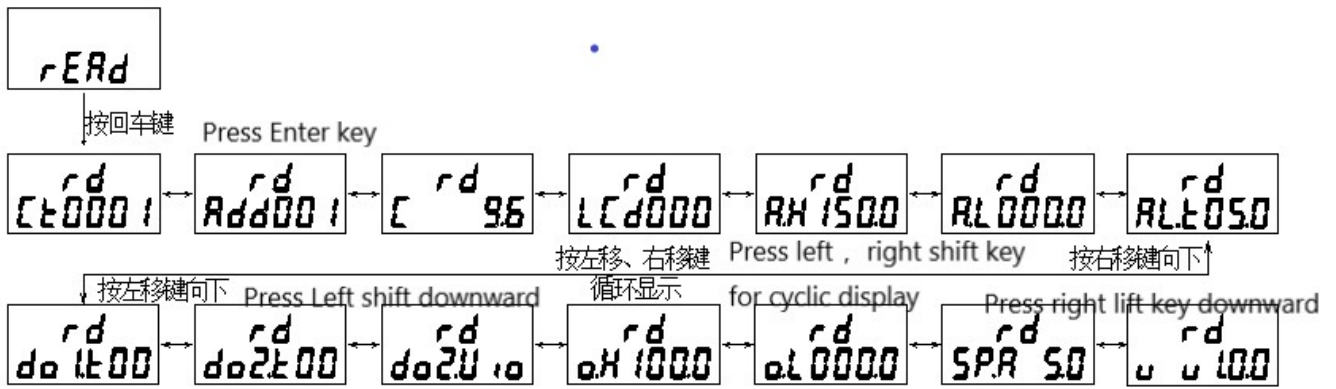

说明：Explanation

电压表菜单与此类似，只有两处不同：1. Pt 替代 Ct；2. SP. U 替代 SP. A。

The voltmeter menu is similar with only two differences: 1.Pt instead of Ct; 2.2. Sp. U replaces SP.A.

PZ72 系列单相直流电流表（PZ72-DI/*）：

PZ72 series single-phase DC ammeter(PZ72-DI/*)：

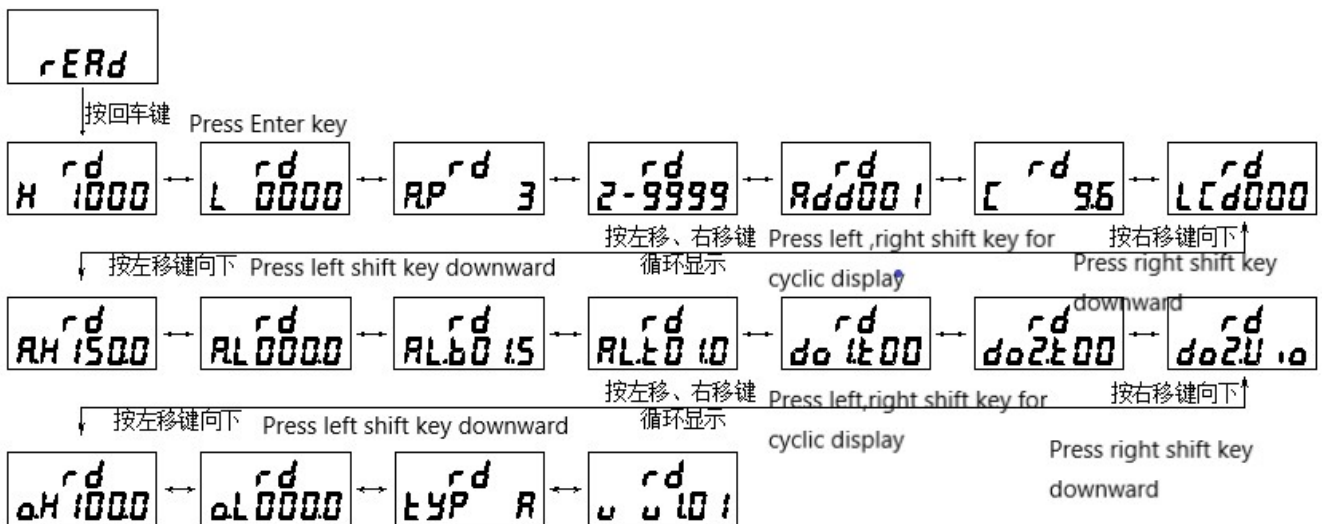

说明：Explanation

直流电压表菜单与此类似，只有一处不同：A. P 替代 U. P；

The DC voltmeter menu is similar except for one difference: a.instead of U.P.

当零点屏蔽值设定为正时，表示显示值在设定范围内都显示为 0，即： $| \text{显示值} | \leq \text{设定值}$ ，显示都为 0（图 5）；当设定值为负时，表示显示值 \leq 设定值时，显示都为设定值（图 6）。

When the zero screen value is set to positive, it means that all display values are displayed as 0 within the set range, that is: $| \text{display value} | \leq \text{set value}$, and all display values are 0 (figure 5);When the set value is negative, it means that the display value \leq the set value, and the display value is set value (Figure 6).



图 5 Figure 5



图 6 Figure 6

PZ48(96)系列单相电流表 (PZ□□-AI/*):

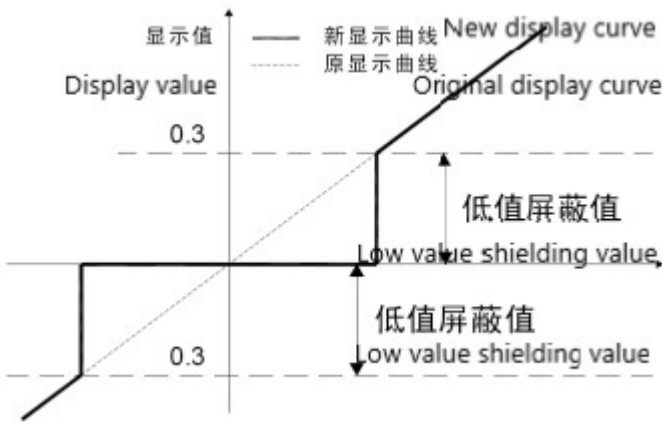
PZ48(96) series single-phase DC ammeter (PZ□□-AI/*):

rERd

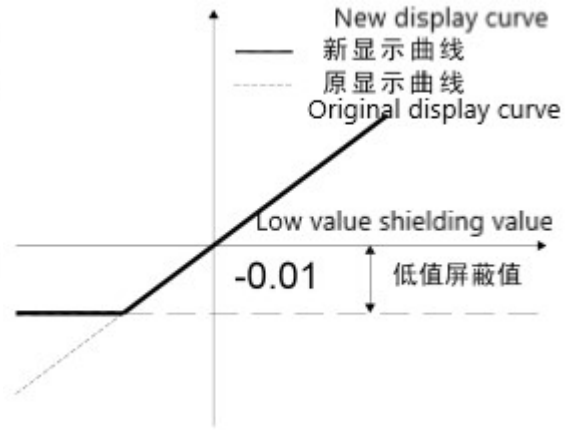
按回车键 Press Enter Key

Ct → Rddr → bRUd → LCd → AL.Hi → AL.Lo → AL.-t

按左移键向上 Press left shift key upward 按左移、右移键 Press left, right shift key for 按右移键向下 Press right key downward

do1.t → do2.t → do2.U → Ro.Hi → Ro.Lo → SP-A → uEr

说明: Explanation

左右键选择需要查看的参数菜单, 按回车键进入查看具体设置值, 按 SET 键返回;

Key left and right to select the parameter menu to be viewed, press enter to see the specific setting value, and press SET to return;

电压表菜单与此类似, 只有两处不同: 1. Pt 替代 Ct; 2. SP. U 替代 SP. A;

Voltmeter and frequency table menus are similar with only two differences: 1. Pt instead of Ct; 2.2. Sp. U replaces SP.A;

48 型: 无 AL. Hi、AL. Lo、AL. -t、do1. t、do2. t 及 do2. U 菜单。

48 type: no menu of AL.Hi, AL.Lo, AL.-t, DO1.t, DO2.t and DO2.U.

PZ72 系列单相电能表 (PZ72-E/*):

PZ72 Series single-phase energy meters (PZ72-E/*):

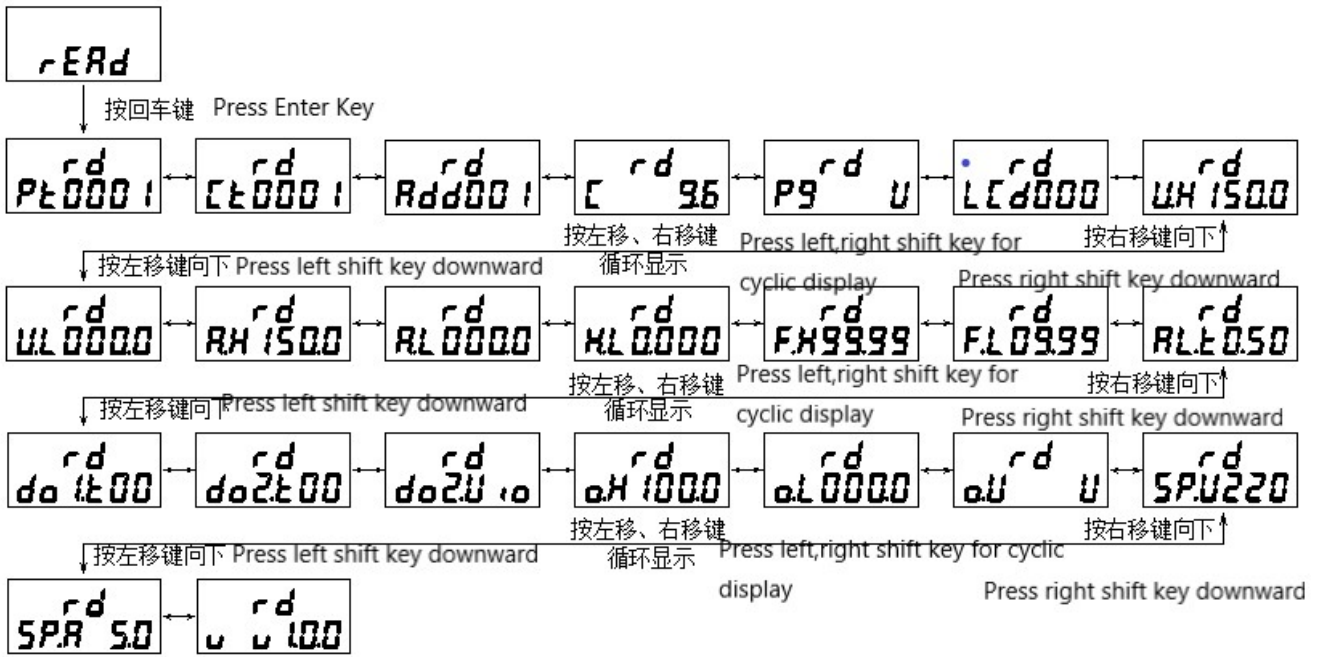

5.3.4 Prog 菜单（可写）Prog menu (writable)

PZ72 系列单相电流表（PZ72-AI/*）：

PZ72 Series single-phase current meters（PZ72-AI/*）：

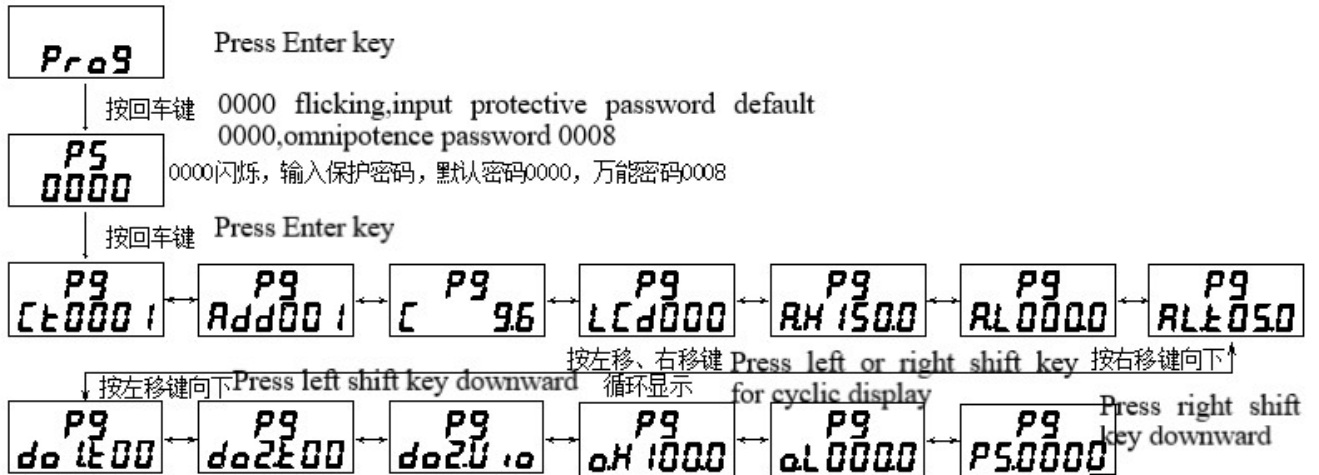

说明：Explanation

Prog 菜单可按左移、右移键切换，按回车键则第二行数据闪烁，表示可修改；修改后按 SET 键放弃修改，按回车键确认修改。确认后再按 SET 键出现闪烁的 SAVE，询问是否保存，保存按回车确认，不保存按 SET 键退出。

Prog menu can be switched by pressing the left shift key or the right shift key. Press the Enter key and the second line of data flashes, indicating that it can be modified. After modification, press SET key to abandon modification and press Enter key to confirm modification. After confirmation, press SET key to display flashing SAVE, and ask whether to SAVE, press Enter to confirm SAVE, and press SET key to exit.

电压表菜单与此类似，只有一处不同：Pt 替代 Ct。

The voltmeter menu is similar except for one difference: Pt instead of Ct.

PZ72 系列单相直流电流表 (PZ72-DI/*):

PZ72 Series single-phase current meters (PZ72-DI/*):

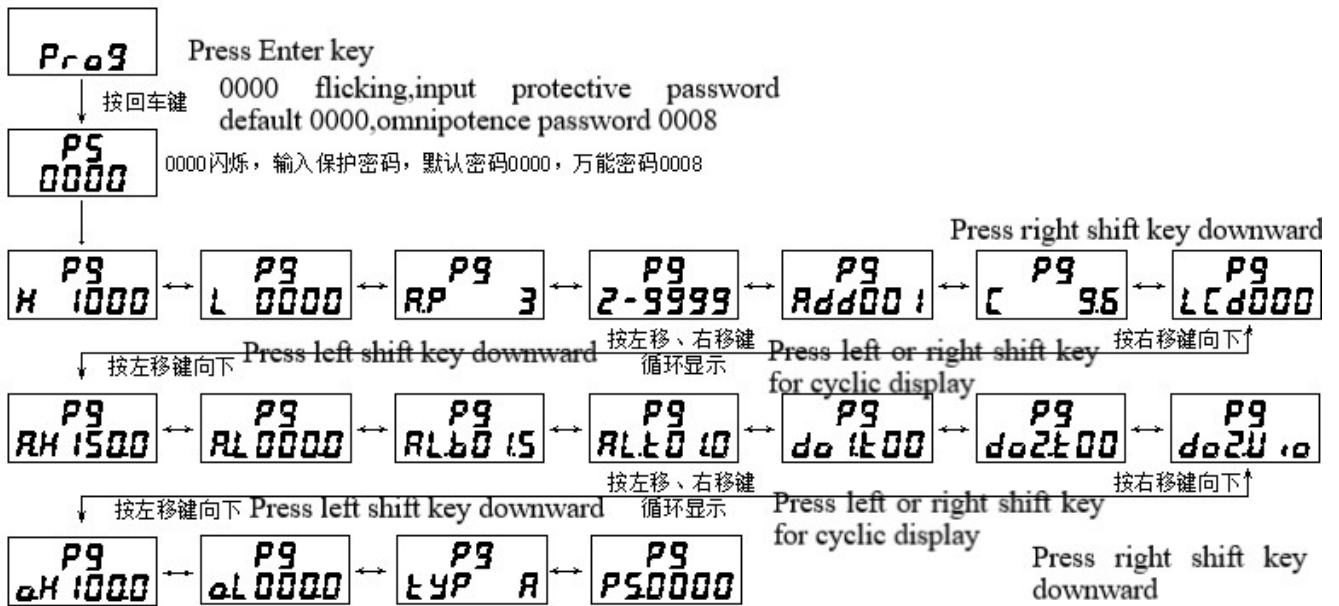

说明: Explanation

Prog 菜单可按左移、右移键切换, 按回车键则第二行数据闪烁, 表示可修改; 修改后按 SET 键放弃修改, 按回车键确认修改。确认后再按 SET 键出现闪烁的 SAVE, 询问是否保存, 保存按回车确认, 不保存按 SET 键退出。

Prog menu can be switched by pressing the left shift key or the right shift key. Press the Enter key and the second line of data flashes, indicating that it can be modified. After modification, press SET key to abandon modification and press Enter key to confirm modification. After confirmation, press SET key to display flashing SAVE, and ask whether to SAVE, press Enter to confirm SAVE, and press SET key to exit.

直流电压表菜单与此类似, 只有一处不同: A. P 替代 U. P;

The DC voltmeter menu is similar except for one difference: a. instead of U. P.

PZ48(96) 系列单相电流表 (PZ□□-AI/*):

PZ48(96) Series single-phase ammeter (PZ□□-AI/*):



说明: Explanation

输入正确密码, 按回车进入 Prog 菜单, 按左、右键选择需要修改的参数, 按回车键进入, 数据闪烁, 可修改; 修改后按回车确认保存, 按 SET 键放弃保存。

Enter the correct password, press Enter to enter the Prog menu, press left and right to select the parameters to be modified, and press Enter to enter. Data flashes and can be modified; Press Enter to confirm saving after modification, and press SET key to give up saving

按 SET 键出现闪烁的 SAVE, 询问是否保存, 如需保存按回车确认, 否则按 SET 键退出不保存。

Press SET key to display flashing SAVE, and ask whether to SAVE. If you need to SAVE, press enter to confirm; otherwise, press SET key to exit without saving.

电压表菜单与此类似, 只有一处不同: Pt 替代 Ct;

The voltmeter menu is similar except for one difference: Pt instead of Ct;

48 型: 无 AL.Hi、AL.Lo、AL.-t、do1.t、do2.t 及 do2.U 菜单。

48 type: no menu of AL.Hi, AL.Lo, AL.-t, DO1.t, DO2.t and DO2.U.

PZ72 系列单相电能表 (PZ72-E/*) :

PZ72 series single-phase electricity meters (PZ72-E/*) :

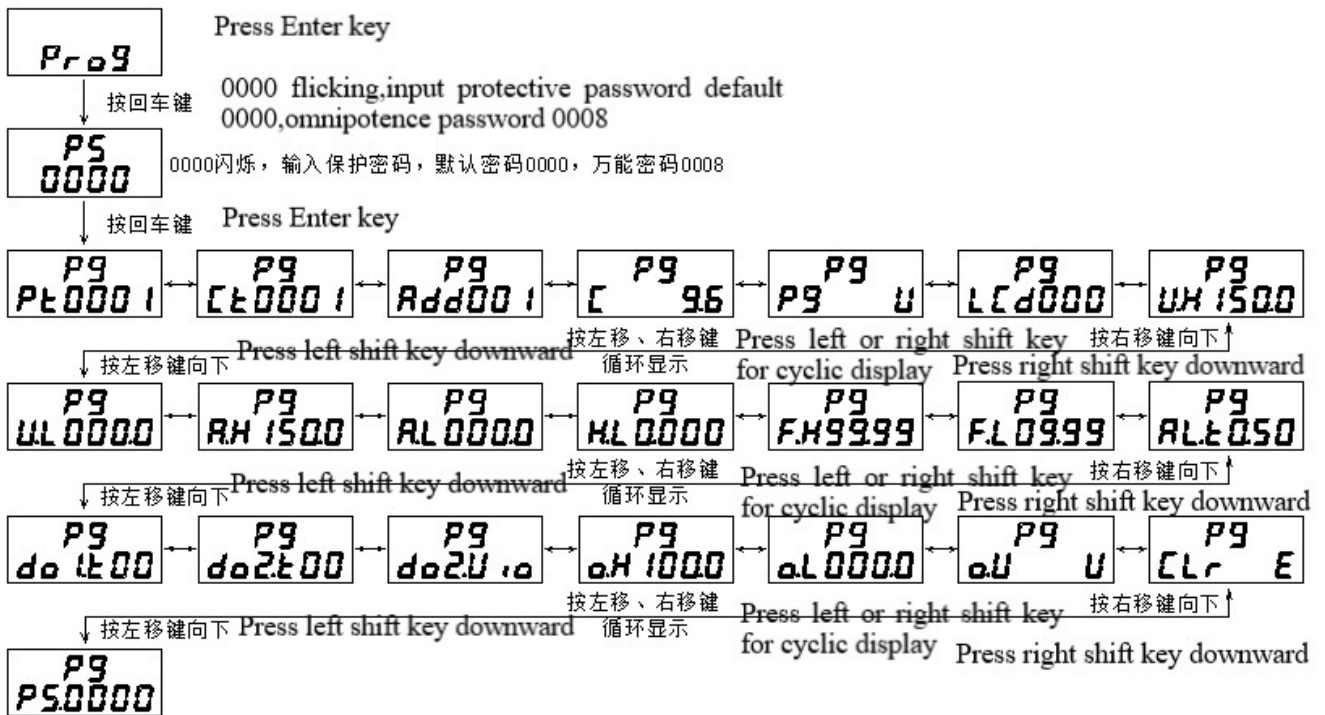

说明: Explanation

Prog 菜单可按左移、右移键切换, 按回车键则第二行数据闪烁, 表示可修改; 修改后按 SET 键放弃修改, 按回车键确认修改。确认后再按 SET 键出现闪烁的 SAVE, 询问是否保存, 保存按回车确认, 不保存按 SET 键退出。

Prog menu can be switched by pressing the left shift key or the right shift key. Press the Enter key and the second line of data flashes, indicating that it can be modified. After modification, press SET key to abandon modification and press Enter key to confirm modification. After confirmation, press SET key to display flashing SAVE, and ask whether to SAVE, press Enter to confirm SAVE, and press SET key to exit.

5.4 功能设置与使用 Function setting and usage

5.4.1 倍率更改设置 Change the multiplier setting

例 1: AC10kV/100V 的电压表: 进入 Prog 菜单, 修改 Pt 为 100;

Example 1: AC10kV/100V voltmeter: enter the Prog menu and change Pt to 100;

计算方法: $10000V \div 100V = 100$

Calculation method: $10000V \div 100V = 100$

例 2: AC500A/5A 的电流表: 进入 Prog 菜单, 修改 Ct 为 100。

Example 2: AC500A/5A ammeter: enter the Prog menu and modify the Ct to 100

计算方法: $500A \div 5A = 100$

Calculation method: $500A \div 5A = 100$

电能表的 Pt、Ct 都可更改。

The Pt and Ct of electricity meters can be changed.

5.4.2 通讯功能及参数设置 Communication function and parameter setting

Modbus-RTU 协议: “9600, 8, n, 1”。

Modbus-rtu protocol: "9600,8, n, 1".

通讯参数见 5.2 菜单符号及意义, 编程流程见 5.3.4, 进入 Prog 菜单。

See 5.2 menu symbol and meaning for communication parameters, 5.3.4 for programming process, and enter Prog menu.

5.4.3 报警功能及参数设置 Alarm function and parameter setting

PZ72 系列仪表报警状态:

PZ72 series meter alarm status:

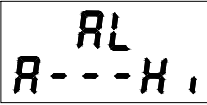
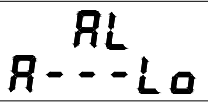
			测量值为 0 时不报警 When the measured value is 0, it will not alarm
正常 Normal	I 过高 I too high	I 过低 I too low	

PZ96 系列仪表报警状态 (正常测量时, 按右移键, 可查看报警信息)

Alarm status of PZ96 series instruments (press the right shift button to view alarm information during normal measurement)

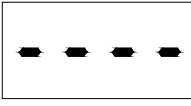
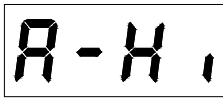
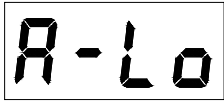
			When the measured value is 0, it will not alarm
正常 Normal	I 过高 I too high	I 过低 I too low	

正常测量时, 有报警产生, 则显示数据会闪烁。如果 Prog 菜单中的 do2.u 设置为 AL, 则报警时会在继电器 DO2 上产生一个输出 (继电器常开接点闭合)。

When the normal measurement, there is an alarm, the display data will flicker. If DO2.u in the Prog menu is set to AL, an output will be produced on relay DO2 when the alarm is raised (normally open contact closure of the relay).

报警状态可通讯读取, 参量地址见 6.4 单相表通讯参量地址表。

The alarm state can be read by communication, and the parameter addresses are shown in the 6.4 single-phase table.

报警功能设置，参数见 5.2 菜单符号及意义，设置流程见 5.3.4 Prog 菜单。

Set the alarm function. See 5.2 Menu symbol and meaning for parameters and 5.3.4 Prog menu for setting process.

报警功能默认为关闭状态，除非客户要求。

The alarm function is off by default unless requested by the customer.

5.4.4 开关量功能及输出控制 Switching function and output control

5.4.4.1 PZ72 系列仪表，正常测量时，按下回车键，可查看开关量状态，如下：

PZ72 series instruments. Press enter to check the status of the switch quantity during normal measurement, as follows:

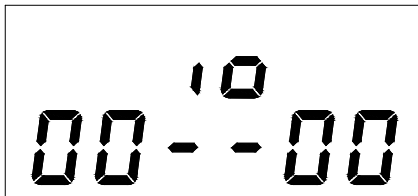

0 表示断开；1 表示闭合 0 means disconnect;One means connect

DI1	DI2	D01	D02
开关量输入		开关量输出	
Switch input		Switch output	

如图开关量输入指示在 DI1、DI2，开关量输出指示在 D01、D02

As shown in the figure, the input indicator of switching value is in DI1 and DI2, and the output indicator of switching value is in DO1 and DO2

另外，液晶 (LCD) 显示方式仪表，在正常测量状态下就有开关量输入/输出指示，无需按快捷键查看。

In addition, liquid crystal (LCD) display mode instrument, in the normal measurement state there is a switch input/output indicator, there is no need to press the shortcut key to check.

在查看开关量状态页面，再次按下回车键，将进入本地开关量输出 (继电器) 控制页面 (与查看页面相同，但开关量输出位闪烁可修改)，左右键输入保护密码 (出厂设置：0000，密码设定见 5.4.8)，回车确认进入，

Press enter again to enter the local output (relay) control page (same as the viewing page, but the output bit of switch flickers and can be modified). Enter the protection password (factory setting: 0000, password setting as shown in 5.4.8) and press enter to confirm entry.

数字闪烁表示可修改，按左键选择需修改项，按右键进行修改，按回车确认修改，按 SET 键放弃修改。

Digital flashing indicates that modification is possible. Press left button to select the item to be modified, press right button to modify, press Enter to confirm modification, and press SET key to abandon modification.

5.4.4.2 PZ96 系列仪表，正常测量时，按下回车键，可查看开关量输入状态，如下：

PZ96 series instruments. Press enter to check the input status of the switch, as follows:

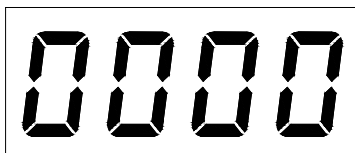

0 表示断开；1 表示闭合 0 means disconnect;One means connect

DI1	DI2	DI3	DI4
开关量输入			
Switch input			

如图开关量输入指示 DI1-DI4，数码管 (LED) 显示方式仪表，其开关量输出 D01、D02 指示在面板上。

As shown in the figure, switch input indicator DI1-DI4, digital tube (LED) display mode instrument, its switch output DO1, DO2 indicator on the panel.

另外，液晶(LCD)显示方式仪表，在正常测量状态下就有开关量输入/输出指示，无需按快捷键查看。

In addition, liquid crystal (LCD) display mode instrument, in the normal measurement state there is a switch input/output indicator, there is no need to press the shortcut key to check.

在查看开关量输入状态页面，再次按下回车键，将进入本地开关量输出(继电器)控制页面，左右键输入保护密码（出厂设置：0000，密码设定见 5.4.8），回车确认进入：

Press enter again to enter the control page of output (relay) of local switching volume. Key left and right to enter the protection password (factory setting: 0000, password setting see 5.4.8). Press enter to enter:

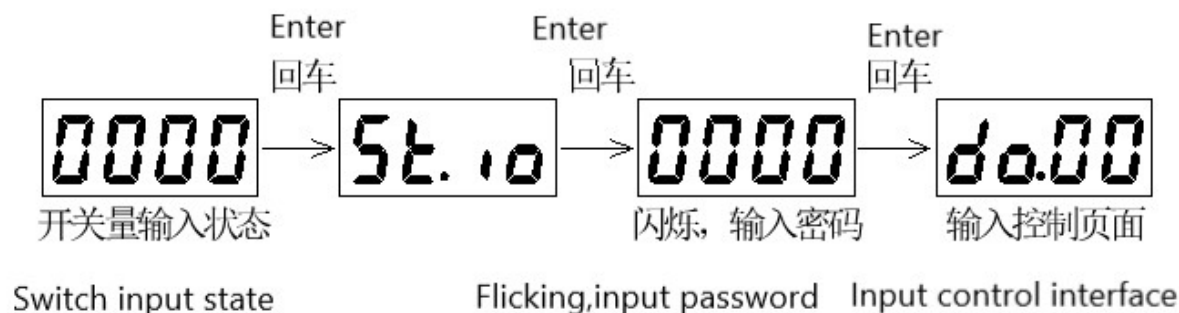

开关量输出控制页面中，数字闪烁表示可修改，左键选择需修改项，右键进行修改（0 表示断开，1 表示闭合），回车确认修改，按 SET 键放弃修改。

In the output control page of switching volume, digital flicker indicates that it can be modified, left button selects items to be modified, right button makes modification (0 means break, 1 means close), press enter to confirm modification, and press SET key to abandon modification.

远程读取与控制见 6.5 通讯应用。

For remote reading and control, see Communication Application 6.5.

开关量输出为继电器常开触点；开关量输入为光电隔离，干接点输入，简要原理如下：

Switching output is normally open contact of relay; Switch input is photoelectric isolation, dry contact input, the brief principle is as follows:

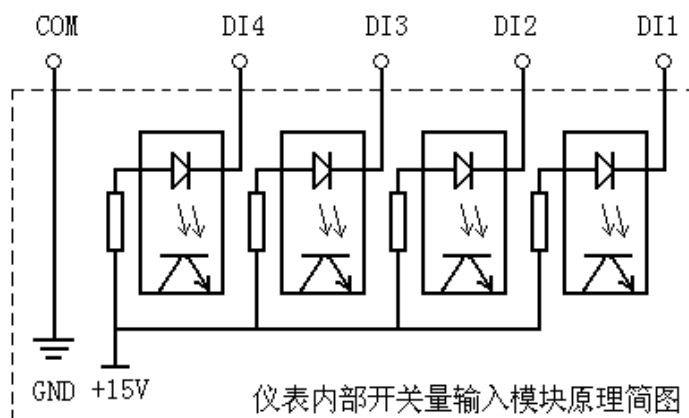

Schematic diagram of switch input module inside the meter

5.4.5 模拟量输出及设置

Analog output and Settings

Ao.L(Ao.Lo)：模拟量下限设置；Ao.H(Ao.Hi)：模拟量上限设置；Ao.U：电能表中此菜单表示模拟量输出选择，可对应所测电网电压、电流、功率等；设置范围见 5.2 菜单符号及意义

Ao.l (AO.LO) : Set the lower limit of analog quantity;Ao.h (AO.HI) : Setting the upper limit of analog quantity;Ao.u: This menu in the watt-hour meter represents the analog output selection, which can correspond to the

measured grid voltage, current, power, etc.; See 5.2 Menu symbol and meaning for setting range

例：AC500/5A，对应输出一路 4-20mA（即，AC0A 对应 4mA；AC500A 对应 20mA）

Example: AC500/5A, corresponding to output 4-20mA (that is, AC0A corresponds to 4mA; AC500A corresponds to 20mA)

设定：Ao.L(Ao.Lo):000 (%)； Ao.H(Ao.Hi): 100 (%)；

Setting: Ao.L(Ao.lo):000 (%);Ao.h (Ao.hi) : 100 (%);

说明：Ao.L(Ao.Lo)、Ao.H(Ao.Hi)的设定值均为额定输入信号的百分数（频率表除外）；

Explanation: The set values of AO.L (AO.LO) and AO.h (AO.HI) are the percentage of the rated input signal (except the frequency table);

频率表变送以测量一次值为变送上下限（如 Ao.L(Ao.Lo):45.00；Ao.H(Ao.Hi): 65.00）。

Frequency table transformer takes the measured primary value as the transformer to send the lower limit (e.g. Ao.l (AO.LO):45.00;Ao. H (Ao. Hi) : 65.00)

5.4.6 脉冲输出功能 Pulse output function

单相电能表为一路脉冲输出功能，一路有功脉冲；输出接口为无源光耦接点，脉冲常数为：15000imp/kWh。

The single-phase watt-hour meter has one pulse output function and one active pulse. The output interface is a passive optocoupler contact, and the pulse constant is 15000IMp /kWh.

5.4.7 液晶背光控制

Liquid crystal backlight control

进入 Prog 菜单，左右键选择 LCD 页面，按回车键进入修改状态；左右键进行液晶背光时间修改 000~250s，此项对 LED 显示仪表无效。

Enter the Prog menu, select LCD page by pressing enter to enter the modification state. The LCD backlight time of the left and right keys is modified by 000 ~ 250s, which is invalid for the LED display instrument.

000：表示液晶背光常亮；

000: indicates that the LCD backlight is always bright;

250：表示液晶背光在按键 250 秒内无操作后，转入微亮状态，以延长背光使用寿命。

250: indicates that the LCD backlight will turn into a slightly bright state after no operation within 250 seconds of the keystroke to extend the service life of the backlight.

5.4.8 编程密码设置 Programming password Settings

进入 Prog 菜单，左键选择 PASS 页面，按回车键进入修改状态；左右键进行密码修改，密码范围 0000~9999，按回车确认修改，按 SET 键放弃修改。修改后，编程保护密码及开关量输出控制保护密码均为新密码。

Enter the Prog menu, left-click the PASS page, and press enter to enter the modification state. Key left and right to modify the password, password range 0000 ~ 9999, press enter to confirm the modification, press SET key to abandon the modification. After modification, both the programming protection password and the switching output control protection password are new passwords.

默认密码：0000；万能密码：0008

Default password: 0000; Universal password: 0008

5.5 测量数据查看

Measurement data viewing

对于单相电流表、电压表，其测量值显示在其初始画面；而 72 外形单相电能表，因测量数据较多，不能同时显示多种数据，在正常测量状态下，可以按左、右键进行查看所测各电量参数。

For single-phase ammeter and voltmeter, the measured value is displayed on the initial screen. However, the single-phase watt-hour meter of 72 shape cannot display multiple data at the same time due to the large number of measurement data. In the normal measurement state, you can press the left or right button to check the measured

electric quantity parameters.

5.5.1 PZ72 系列 LED 显示电能表测量数据查看

PZ72 series LED display meter measurement data check



LED 电能表测量数据查看流程

Checking flow chart of measurement data of LED meter

说明: Explanation

- | | |
|--|---|
| U: 电压值 (一次侧), 单位: 伏特 (V) | A: 电流值 (一次侧), 单位: 安培 (A) |
| U: Voltage value (primary side), unit: Volt (V) | A: Current value (primary side), unit: ampere (A) |
| F: 频率值, 单位: 赫兹 (Hz) | P: 有功功率 (一次侧), 单位: 千瓦 (kW) |
| F: Frequency value, in Hertz (Hz) | P: Active power (primary side), unit: kW |
| Q: 无功功率 (一次侧), 单位: 千乏 (kvar) | H: 功率因数 |
| Q: Reactive power (primary side), unit: KVAR | H: Power factor |
| Ep: 有功电能 (一次侧), 单位: 千瓦时 (kWh) | Eq: 无功电能, 单位: 千乏时 (kvarh) |
| Ep: Active power (primary side), unit: Kilowatt-hour (kWh) | Eq: Reactive power, unit: thousand hours (kvarh) |
| AL: 报警信息 | |
| AL: Alarm information | |

当电能显示为一次侧时, 数据超过 999999999 时, 显示自动循环显示, 高位显示字符 H, 低位显示字符 L。
When the electric energy is displayed as the primary side, when the data exceeds 999999999, the automatic cycle display, the high character H and the low character L will be displayed.

5.5.2 PZ72 系列 LCD 显示电能表测量数据查看

PZ72 series LCD display meter measurement data view

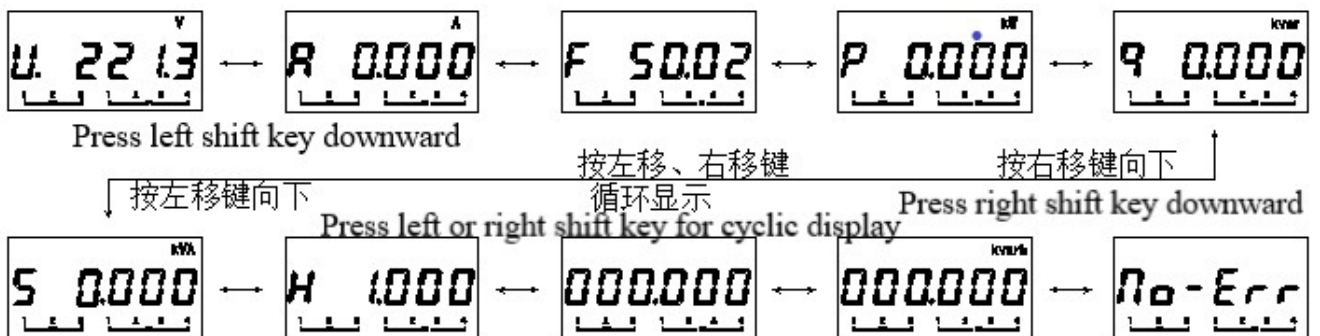

LCD 电能表测量数据查看流程

Checking flow chart of measurement data of LCD meter

说明: Explanation

液晶表测量数据查看流程基本与数码管显示仪表一致, 因显示方式的不同, 两者略有不同。

The flow chart of measuring data of LIQUID crystal meter is basically the same as that of digital tube display meter.

当电能数据超过 999999999 时, 显示分 2 行自动循环显示, 高位显示字符 H, 低位显示字符 L。

When the power data exceeds 999999999, the display will be divided into 2 lines of automatic circulation display, high display character H, low display character L.

6 通讯指南 Communication guide

6.1 概述 Overview

PZ 系列仪表采用 Modbus-RTU 协议: “9600, 8, n, 1”, 其中 9600 为默认波特率, 可通过编程修改为 2400、4800、19200 等, 设置方法见本说明书 5.4.3 通讯参数设置; 8 表示有 8 个数据位; n 表示无奇偶校验位; 1 表示有 1 个停止位。

PZ series meters adopt MODBUS-RTU protocol: "9600, 8, N, 1", wherein 9600 is the default baud rate, which can be modified by programming to 2400, 4800, 19200, etc. See 5.4.3 Communication parameter setting in this manual for setting methods. Eight means there are eight data bits; N is for parity; One means there is a stop bit.

错误检测: CRC16 (循环冗余校验)

Error detection: CRC16 (Cyclic redundancy check)

6.2 协议 Protocol

当数据帧到达终端设备时, 它通过一个简单的“端口”进入被寻址到的设备, 该设备去掉数据帧的“信封”(数据头), 读取数据, 如果没有错误, 就执行数据所请求的任务, 然后, 它将自己生成的数据加入到取得的“信封”中, 把数据帧返回给发送者。返回的响应数据中包含了以下内容: 终端从机地址 (Address)、被执行了的命令 (Function)、执行命令生成的被请求数据 (Data) 和一个 CRC 校验码 (Check)。发生任何错误都不会有成功的响应, 或者返回一个错误指示帧。

When data frames to terminal equipment, it by a simple "ports" to be addressed to the device, the device to remove the "envelope" data frames (data), read the data, if there are no mistakes, will carry out the tasks of the requested data, then, it will generate its own data to join the "envelope" of the data frame is returned to the sender. The response Data returned contains the terminal slave Address, the executed command (Function), the requested Data generated by the executed command, and a CRC Check. Any error occurs without a successful response, or an error indication frame is returned.

(12)

6.2.1 数据帧格式 Data frame format

地址 Address	功能 Function	数据 Data	校验 Check
8-Bits	8-Bits	N×8-Bits	16-Bits

6.2.2 地址 (Address) 域 Address field

地址域在帧首, 由一个字节 (8-Bits, 8 位二进制码) 组成, 十进制为 0~255, 在我们的系统中只使用 1~247, 其它地址保留。这些位标明了用户指定的终端设备的地址, 该设备将接收来自与之相连的主机数据。同一总线上每个终端设备的地址必须是唯一的, 只有被寻址到的终端才会响应包含了该地址的查询。当终端发送回一个响应, 响应中的从机地址数据便告诉了主机哪台终端正与之进行通信。

The address field is composed of one byte (8-bit, 8-bit binary code) at the beginning of the frame. The decimal system is 0 to 255. In our system, only 1 to 247 is used, and other addresses are reserved. These bits indicate the address of the user-specified terminal device, which will receive data from the host to which it is connected. The address of each terminal device on the same bus must be unique, and only the terminal addressed to will respond to a

query containing that address. When a terminal sends back a response, the slave address data in the response tells the host which terminal is communicating with it.

6.2.3 功能 (Function) 域 Function field

功能域代码告诉了被寻址到的终端执行何种功能。下表列出了该系列仪表用到的功能码，以及它们的意义和功能。

Function field code tells the addressable terminal what function to perform. The following table lists the function codes used in this series of instruments, as well as their meanings and functions.

代码 (十六进制) Code (hexadecimal)	意义 Meaning	行 为 Action
03H	读取保持寄存器 Read hold register	在一个或多个保持寄存器中取得当前的二进制值 Gets the current binary value in one or more hold registers
10H	预置多寄存器 Preset multiple registers	把具体的二进制值装入一串连续的保持寄存器 To load specific binary values into a sequence of hold registers

6.2.4 数据 (Data) 域 Data field

数据域包含了终端执行特定功能所需的数据或终端响应查询时采集到的数据。这些数据可能是数值、参量地址或者设置值。

Data field contains the data required by the terminal to perform a specific function or the data collected when the terminal responds to a query. The data may be numerical values, parametric addresses, or setting values.

例如：功能域告诉终端读取一个寄存器，数据域则需要指明从哪个寄存器开始及读取多少个数据，内嵌的地址和数据依照类型和从机之间的不同而内容有所不同。

For example, a function field tells a terminal to read a register, while a data field needs to indicate which register to start from and how much data to read. The embedded address and data vary in content according to the type and the slave.

6.2.5 错误校验 (Check) 域 Check field

该域采用 CRC16 循环冗余校验，允许主机和终端检查传输过程中的错误。有时由于电噪声和其它干扰，一组数据从一个设备传输到另一个设备时，在线路上可能会发生一些改变，错误校验能够保证主机或从机不去响应那些发生改变的数据，这就提高了系统的安全性、可靠性和效率。

The domain USES CRC16 cyclic redundancy check, which allows the host and terminal to check for errors during transmission. Sometimes due to electrical noise and other interference, when a group of data is transmitted from one device to another, some changes may occur on the line. Error checking can ensure that the host or slave does not respond to the changed data, which improves the security, reliability and efficiency of the system.

6.3 错误校验的方法 Error checking method

错误校验 (CRC) 域占用两个字节，包含了一个 16 位的二进制值。CRC 值由传输设备计算出来，然后附加到数据帧上，接收设备在接受数据时重新计算 CRC 值，然后与接收到的 CRC 域中的值进行比较，如果这两个值不相等，就发生了错误。

The error check (CRC) field occupies two bytes and contains a 16-bit binary value. The CRC value is calculated by the transmitting device and then attached to the data frame. The receiving device recalculates the CRC value as it receives the data and then compares it with the value in the RECEIVED CRC field. If the two values are not equal, an error occurs.

CRC 运算时，首先将一个 16 位的寄存器预置为全 1，然后连续把数据帧中的每个字节中的 8 位与该寄存器的当前值进行运算，仅仅每个字节的 8 个数据位参与生成 CRC，起始位和停止位以及可能使用的奇偶位都不影响 CRC。在生成 CRC 时，每个字节的 8 位与寄存器中的内容进行异或，然后将结果向低位移位，高位则用“0”补充，最低位（LSB）移出并检测，如果是 1，该寄存器就与一个预设的固定值（0A001H）进行一次异或运算，如果最低位为 0，不作任何处理。

During CRC operation, a 16-bit register is preset to all 1, and then the 8 bits in each byte of the data frame are computed continuously with the current value of the register. Only the 8 bits of each byte participate in generating CRC, and the starting and stopping bits and the possible parity bits do not affect CRC. When generate CRC, each byte of eight different or with the contents of the registers, then the results to the low displacement, high use "0", its lowest (LSB) removed and test, if it is 1, the register is fixed with a preset value (0 a001h) for an exclusive or operation, if the lowest is 0, do not make any processing.

CRC 生成流程:

CRC generation process:

1 预置一个 16 位寄存器为 0FFFFH（全 1），称之为 CRC 寄存器。

A 16-bit register with 0FFFFH (all 1) is preset and is called the CRC register.

2 把数据帧中的第一个字节的 8 位与 CRC 寄存器中的低字节进行异或运算，结果存回 CRC 寄存器。

The 8-bit of the first byte in the data frame is xor with the low byte in the CRC register, and the result is saved back to the CRC register.

3 将 CRC 寄存器向右移一位，最高位填 0，最低位移出并检测。

The CRC register is moved to the right one bit, the highest bit is filled with 0, the lowest bit is removed and detected.

4 如果最低位移出为 0：重复第 3 步（下一次移位）；如果最低位移出为 1：将 CRC 寄存器与一个预设固定值（0A001H）进行异或运算。

If the minimum displacement is 0: repeat step 3 (next shift); If the minimum displacement is 1: Xor the CRC register with a preset fixed value (0A001H).

5 重复第 3 步和第 4 步直到 8 次移位。这样就处理完了一个完整的 8 位。

Repeat steps 3 and 4 until 8 shifts. This completes a full 8 bits.

6 重复第 2 步到第 5 步来处理下一个 8 位，直到所有的字节处理结束。

Repeat steps 2 through 5 to process the next 8 bits until all bytes are processed.

7 最终 CRC 寄存器的值就是 CRC 的值。

The final CRC register value is the CRC value.

此外还有一种利用查表计算 CRC 的方法，它的主要特点是计算速度快，但是表格需要较大的存储空间，该方法此处不再赘述，请查阅相关资料。

In addition, there is another method to calculate CRC by looking up table. Its main characteristic is that the calculation speed is fast, but the table needs a large storage space. This method is not repeated here, please refer to the relevant data.

6.4 单相表通讯参量地址表 (Word)

Single-phase Table Communication Parameters Address Table (Word)

地址 Address	内容 Content	简要说明 Brief description	读写属性: R — 读; W — 写 除地址 0012H 为部分可写外, 均为只读; Read and write properties: R - read; W - write, except address 0012H is partially writable, are read-only;	
0000H	U 有效值 U RMS	电压 (单位: V) Voltage (unit: V)	电能数据为一次侧数据; 无需再乘电压及电流倍率; Energy data is primary side data; No need to multiply voltage and current ratio;	
0001H	U 指数位 U index bit	交流: 0~9999 AC:0~9999 直流: -9999~9999 DC:-9999~9999		
0002H	I 有效值 I RMS	电流 (单位: A) Current (unit: A)		
0003H	I 指数位 I index bit	交流: 0~9999 AC:0~9999 直流: -9999~9999 DC:-9999~9999		
0004H	F 有效值 F RMS	频率 (单位: Hz) Frequency (Unit: Hz)		
0005H	F 指数位 F index bit			
0006H	H 有效值 H RMS	功率因数 Power factor -1~1		
0007H	H 指数位 H index bit			
0008H	P 有效值 P RMS	有功功率 (单位: W) Active power (unit: W) -9999~9999		除功率因数、有功功率、无功功率的有效值外, 其它数据均为无符号数 Except for the effective values of power factor, active power and reactive power, all other data are unsigned numbers
0009H	P 指数位 P index bit			
000aH	Q 有效值 Q RMS	无功功率 (单位: var) Reactive power (unit: var) -9999~9999		
000bH	Q 指数位 Q index bit			
000cH	Ep 高位 Ep upper bit	有功电能 (单位: Wh) Active energy (Unit: Wh) 0~4199999999		
000dH	Ep 低位 Ep low bit			
000eH	Eq 高位 Eq upper bit	无功电能 (单位: varh) Reactive energy (VARH) 0~4199999999		
000fH	Eq 低位 Eq low bit			
0010H	Pt	电压变比 Voltage ratio		
0011H	Ct	电流变比 Current ratio		
0012H	报警及 I/O Alarm and I/O	详细说明见下方 See below for more details		
0013H	此后为保留字 After that, it is reserved			

说明: Explanation

电压、电流、功率等数据数值计算方法: (例见: 6.5.1 读数据)

Calculation method of voltage, current, power and other data: (for example: 6.5.1 Read data)

读数 = 有效值×10E (指数位-3)

Reading = effective value ×10E (exponential bit -3)

0012H:报警及开关量输入/输出状态字:

Alarm and switch input/output Status word:

15	...	10	9	8	7	6	5	4	3	2	1	0
—		AL. L	AL. H	DI1	DI2	—		—		D01		D02
(R) 高、低报警指示 (R) High, low alarm indication				(R) 1 闭合, 0 断开 (R) 1 connect, 0 disconnect				(R/W) 1 闭合, 0 断开 (R/W) 1 connect, 0 disconnect				

72 电能表报警状态字: Alarm status of energy meter

15	...	13	12	11	10	9	8	7	...	0
—		H. L		A. -H	A. -L	U. -H	U. -L	开关量输入/输出状态		
		功率因数低报警 Low power factor alarm		电流高、低报警 Current high, low alarm		电压高、低报警 Voltage high, low alarm		与上表同 Same with the table above-mentioned		

说明: ① — 表示保留字或保留位。

Explanation: ① — Represents a reserved word or reserved bit

② 报警标志位: 1 为有报警, 0 为无报警。

② Alarm sign position: 1 is alarm, 0 is no alarm.

6.5 通讯应用 Communication Application

本节所举实例尽可能采用下表格式 (数据为 16 进制)

The examples in this section use the following tabular format (in hexadecimal data) whenever possible

Addr	Fun	Data start		Data #of		CRC16	
		reg Hi	reg Lo	reg Hi	reg Lo	Lo	Hi
01H	03H	00H	00H	00H	06H	C5H	C8H
地址 Address	功能码 Function code	数据起始地址 Data starting address		数据读取个数 Data read quantity		循环冗余校验码 Cyclic redundancy check code	

6.5.1 读数据 Read data

例 1: 读单相电流数据

Example 1: Reading single-phase current data

查询数据帧 Query data frame	01 03 00 02 00 02 65 cb
返回数据帧 Return data frame	01 03 04 03 b2 00 00 5a 50

说明: Explanation

01: 从机地址

01: Slave address

03: 功能码

03: Function code

04: 十六进制, 十进制为 4, 表示后面有 4 个字节的数据

04: Hexadecimal, decimal number 4, means 4 bytes of data

5a 50: 循环冗余校验码

5A 50: Cyclic redundancy check code

数据处理方法见：6.4 通讯参量地址表

Data processing method is shown in the address table 6.4 of communication parameters

处理如下：03 b2(16 进制) = 946 (10 进制)

03 B2 (hexadecimal) = 946 (hexadecimal)

00 00(16 进制) = 0 (10 进制)

00(hex) = 0(hex)

计算： $946 \times 10^{-3} = 0.946$;

Calculation: $946 \times 100^{-3} = 0.946$;

单位：安培 (A)

Unit: Ampere (A)

则仪表显示：

Then the meter shows:

I	0.946
---	-------

读电压表数据与读电流表类似，但起始地址为 00H，查询帧：01 03 00 00 00 02 c4 0b

Reading voltmeter data is similar to reading ammeter, but starting address is 00H, query frame: 01 03 00 00 00 02 C4 0b

读其它信息的查询帧与此格式相同，各信息地址见 6.4 单相表通讯参量地址表。

Check frame for reading other information is the same as this format. For each information address, see the address table of communication parameters in 6.4 single-phase table.

例 2：读有功电能数据

Example 2: Read active power data

查询数据帧	
Check data frame	01 03 00 0c 00 02 04 08
返回数据帧	
Return data frame	01 03 04 00 00 30 26 6f e9

数据处理：

Data processing:

高位：00 00(16 进制) = 0 (10 进制)

High order: 00 00(hexadecimal) = 0(hexadecimal)

低位：30 26(16 进制) = 12326 (10 进制)

Low order: 30 26(hexadecimal) = 12326 (decimal)

因此该仪表一次测有功电能为： $(0 \times 65536 + 12326) / 1000 = 12.326$ 单位：kWh

Therefore, the active power measured by the meter is $(0 \times 65536 + 12326) / 1000 = 12.326$ unit: kWh

无功电能作相同处理；如需二次测电能数据，请自行除以电压、电流变比。

Reactive energy is treated in the same way; If you need to measure the power data twice, please divide the voltage and current ratio by yourself.

6.5.2 写数据 Write data

例 3: 开关量输出远程控制 (控制字: 0012H)

Example 3: Remote control of switching output (control word: 0012H)

写入数据帧 Write data frame	01 10 00 12 00 01 02 00 02 24 e3 (D01 闭合)
	01 10 00 12 00 01 02 00 02 24 e3 (DO1connect)
	01 10 00 12 00 01 02 00 01 64 e2 (D02 闭合)
	01 10 00 12 00 01 02 00 01 64 e2 (DO2 connect)
	01 10 00 12 00 01 02 00 03 e5 23 (D01、D02 闭合)
	01 10 00 12 00 01 02 00 03 e5 23 (DO1、DO2 connect)
返回数据帧 Return data frame	01 10 00 12 00 01 A1 CC (不成功, 无返回)
	01 10 00 12 00 01 A1 CC (unsuccessful, no return)

说明: Explanation

向开关量输出状态位远程写入 1, 则闭合; 写入 0, 则断开。

If 1 is written remotely to the output state bit of the switch, it is connect; Write 0 is disconnect.

当继电器闭合持续时间为非 0 时 (0 为长闭), 继电器闭合持续时间为所设值。

When the relay closure duration is non-0 (0 is long connect), the relay closure duration is set.

总部：安科瑞电气股份有限公司
Headquarter: Acrel Co., Ltd.
地址：上海市嘉定区育绿路 253 号
Address: 253 Yulv Road, Jiading District, Shanghai
电话：(86) 021-69158300 69158301 69158302
Telephone : (86)021-69158300 69158301 69158302
传真：(86) 021-69158303
Fax: (86)021-69158303
服务热线：800-820-6632
网址：www.acrel.cn
Website: www.acrel.cn
邮箱：ACREL001@vip.163.com
Email: ACREL001@vip.163.com
邮编：201801
ZIP code: 201801
生产基地：江苏安科瑞电器制造有限公司
Manufacturing base: Jiangsu Acrel Electrical Manufacturing Co., LTD.
地址：江阴市南闸街道东盟路 5 号
Address: No.5 Dongmeng Road, Nanzha Street, Jiangyin City
电话(传真)：(86) 0510-86179970
Telephone (Fax)：(86) 0510-86179970
邮编：214405
ZIP code: 214405
邮箱：JY-ACREL001@vip.163.com
Email: JY-ACREL001@vip.163.com

修改记录:

日期	修改前	修改后	修改内容
2020.1.6	V1.0	V1.1	1.48, 72, 96 外形增加频率表
2020.1.6	V1.1	V1.2	2.48、96 外形去掉 F 频率测量