

ASD500 开关柜综合测控装置
ASD500 switch cabinet integrated
measuring and control device

安装使用说明书 V1.2

Installation and operation instruction V1.2

申 明

DECLARATION

版权所有，未经本公司之书面许可，此手册中任何段落，章节内容均不得被摘抄、拷贝或以任何形式复制、传播，否则一切后果由违者自负。

本公司保留一切法律权利。

No part of this publication may be reproduced, stored in a retrieval system, or transmitted in any form by any means, electronic, mechanical photocopying, recording, or otherwise without prior permission of Acrel. All rights reserved.

本公司保留对本手册所描述之产品规格进行修改的权利，恕不另行通知。

订货前，请垂询当地代理商以获悉本产品的最新规格。

This company reserve power of revision of product specification described in this manual, without notice. Before ordering, please consult local agent for the latest specification of product.

目 录

Contents

1 安装使用指南	1
1 Installation and operation guide	1
1.1 产品概述	1
1.1 Product overview	1
1.2 型号说明	1
1.2 Description of types	1
1.3 产品型号及功能	3
1.3 Product model and function	3
1.4 技术指标	4
1.4 Technical indexes	4
1.5 产品安装	5
1.5 Product installation	5
1.5.1 安装方法	5
1.5.1 Installation method	5
1.5.2 开孔尺寸（单位：毫米）	6
1.5.2 Hole size (unit: mm)	6
1.5.3 无线温度传感器的安装	6
1.5.3 Installation of wireless temperature transceiver	6
1.5.4 注意事项	8
1.5.4 Precautions	8
1.6 接线方法	9
1.6 Wiring method	9
1.6.1 接线端子	9
1.6.1 Wiring terminal	9
1.6.2 典型接线图	10
1.6.2 Typical wiring diagram	10
2 产品操作指南	11
2 Product operation guide	11
2.1 显示介绍	12
2.1 Display introduction	12
2.2 操作介绍	13
2.2 Operation introduction	13
2.2.1 装置上电	13
2.2.1 Device power-on	13
2.2.2 动态模拟图	13
2.2.2 Dynamic mimetic diagram	13
2.2.3 高压带电显示及闭锁	14
2.2.3 HV live displaying and lock	14
2.2.4 报警继电器输出	15
2.2.4 Alarm relay output	15

2.2.5 温湿度控制	16
2.2.5 Auto temperature and humidity control	16
2.2.6 无线测温	17
2.2.6 Wireless temperature measurement	17
2.2.7 智能语音提示	20
2.2.7 Intelligent voice prompt	20
2.7.7.2 带电语音提示	20
2.7.7.2 live voice prompt	20
2.2.8 柜内照明功能	21
2.2.8 Cabinet lighting function	21
2.2.10 电力参数测量	21
2.2.10 Electric power parameter measurement	21
2.2.11 带电显示自检	23
2.2.11 Self-inspection of live displaying	23
2.2.12 核相功能	23
2.2.12 Nuclear phase function	23
3 通讯指南	23
3 Communication guide	23
3.1 通讯格式详解	24
3.1 Detailed explanation of communication format	24
3.1.1 读取数据 (功能码 03H/04H)	24
3.1.1 Reading data (function code 03H/04H)	24
3.1.2 预置单个寄存器 (功能码 06H)	25
3.1.2 Preset single register (function code 06H)	25
3.1.3 预置多个寄存器 (功能码 10H)	25
3.1.3 Preset several registers (function code 10H)	25
3.2 参量地址表	26
3.2 Parameter address table	26
4 常见故障的诊断分析与排除方法	37
4 Diagnostic analysis and troubleshooting of common faults	37
4.1 辅助电源故障	37
4.1 Fault of auxiliary power supply	37
4.2 环境温湿度显示故障	38
4.2 Fault of environment temperature and humidity display	38
4.3 告警继电器动作故障	38
4.3 Fault of alarm relay operation	38
4.4 一次模拟状态指示灯故障	38
4.4 Fault of primary simulated status indicator light	38
4.5 通信故障	39
4.5 Communication fault	39
4.6 节点温度值显示故障	39
4.6 Fault of node temperature value display	39

1 安装使用指南

1 Installation and operation guide

1.1 产品概述

1.1 Product overview

ASD500 开关柜综合测控装置用于 3~35kV 户内开关柜，适用于中置柜、手车柜、固定柜、环网柜等多种开关柜。具有一次回路模拟图及开关状态指示，高压带电显示及核相，自动温湿度控制，加热回路故障告警，分合闸回路完好指示、分合闸回路电压测量、预分预合闪光指示、电气节点无线测温，人体感应自动照明，语音提示，电参数测量，RS485 及以太网通讯接口等众多功能，集操作、显示于一体。

ASD series switch cabinet integrated measuring and control device is used for 3-35kV indoor switch cabinet, applying to centrally installed switchgear, trolley cabinet, fixed switchgear, ring main unit and other various switch cabinets. With primary circuit mimetic diagram and switch status indicator, HV live displaying and nuclear phase, automatic temperature and humidity control, heating circuit fault alarm, wireless temperature measurement, tripping circuit and closing circuit supervising, tripping circuit and closing circuit control voltage measurement, pre-tripping circuit and pre-closing indication, body induction auto lighting, voice prompt, electrical parameter measurement and RS485, Ethernet communication interface and other functions, it has integrated operation and display into one.

1.2 型号说明

1.2 Description of types



图 1.1 ASD 系列产品命名规则

Figure1.1 ASD Series Product naming rule

1.3 产品型号及功能

1.3 Product model and function

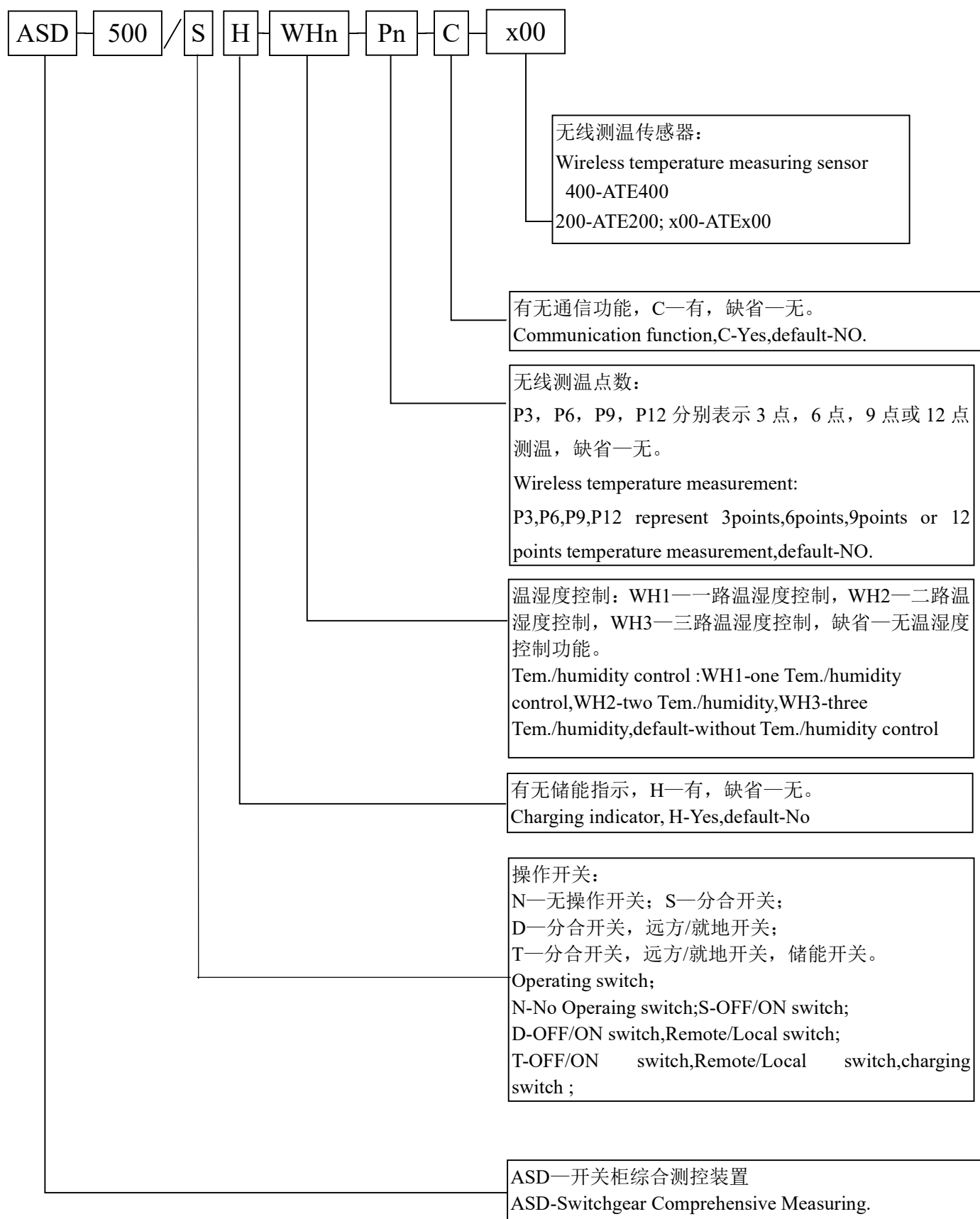
表 1 ASD500 产品型号及功能

Table1 ASD 500 Product specification and functions

型号Type 功能项 function	ASD500
产品图片 Product picture	
开孔尺寸 Cut-out dimensions	220mm×165mm
一次模拟图 Primary circuit analog chart	标配 Standard
带电显示及自检/核相 Live display and self-test/nuclear phase	标配 Standard
电磁闭锁出口 Electromagnetic lockout outle	一路 Configuration 1
温湿度控制 Temp./humidity control	标配 1 路传感器,线长 4 米 Standard 1 sensor,line lengh 4meters
	三路加热, 一路鼓风 Three heating, One blowing
强制加热 Forced heating	标配 Standard
加热回路故障告警 Heating circuitFault alarm	标配 Standard
断电告警 Power off alarm	标配 Standard
语音提示 Voice prompts	标配 Standard
人体感应探头 Sensing probe for humanbody	标配 Standard
操作旋钮 Operating knob	可选 Optional
断路器分合次数显示 Beaker frequency shows	标配 Standard
预分预合闪光指示 pre-tripping circuit and pre-closing indication	可选 Optional (该功能仅限于配有带预分、预合功能的操作开关装置) (This function only takes effect when there is a pre-tripping circuit and

	pre-closing indication switch)
分闸、合闸完好指示 tripping circuit and closing circuit supervising,	标配 Standard
分合闸回路电压测量 tripping circuit and closing circuit control voltage measurement	标配 Standard
无线测温 Wireless temperature measurement	标配 Standard
主回路电力参数测量 Measure and display of power parameter	标配 Standard
RS485 通讯接口 Communication port	标配 2 路 Standard
以太网接口	标配 1 路 Standard
4-20mA输出 4-20mA Reput	标配 2 路 Standard
IRIG-B对时接口	标配 1 路 Standard

1.4 技术指标

1.4 Technical indexes

表 2 ASD500 技术指标

Table2 ASD500 Series Technical data

项目 Item		指标 Value
		ASD500
额定输入 Rated input	接线方式 Wiring mode	3P3L 或 3P4L 3P3L or 3P4L
	电压 Voltage	100V
	电流 Current	5A
	频率 frequency	50Hz
准确度 Accuracy rating	电流、电压 Current、Voltage	0.5 级 0.5 class
	有功功率、无功功率 Active power、 Reactive power	
	电能 Energy	

	分合闸回路电压 tripping circuit and closing circuit control voltage	1 级 1 class
	环境温度 Environment temperature	$\pm 1^{\circ}\text{C}$
	相对湿度 Relative humidity	$\pm 3\%$
装置工作电源 Device Working power		AC 85~265V, DC 100~300V
功耗 Power consumption	辅助电源 Auxiliary power	$\leq 8\text{VA}$
	电压输入 Voltage input	$\leq 0.5\text{VA}$
	电流输入 Current input	$\leq 1\text{VA}$
通讯 Communication	协议 protocol	MODBUS-RTU、MODBUS-TCP
	波特率(bps) Baud rate(bps)	2400、4800、9600、19200
无线测温 Wireless temperature measurement	测温范围 Temperature measurement range	$-50^{\circ}\text{C}\sim+125^{\circ}\text{C}$
	测温精度 Temperature measurement accuracy	$\pm 1^{\circ}\text{C}$
	传感器电池寿命 Sensor battery life	≥ 5 年 (25 $^{\circ}\text{C}$) ≥ 5 year (25 $^{\circ}\text{C}$)
	传感器启动电流 starting current	$\geq 5\text{A}$
环境要求 Environmental requirement	工作温度 Operating temperature	$-10^{\circ}\text{C}\sim 55^{\circ}\text{C}$
	相对湿度 Relative humidity	$\leq 95\%$
平均无故障工作时间 Average work time without stoppage		≥ 50000 小时 ≥ 50000 hour

1.5 产品安装

1.5 Product installation

ASD500 开关柜综合测控装置采用面板嵌入式安装，首先柜体盘面上制作规定尺寸的长方形槽孔，装置取下支架后嵌入槽孔，再用支架固定即可。

Panel embedded installation is adopted for ASD series switch cabinet integrated measuring and control device: firstly fabricate rectangular slot with stipulated size on cabinet face; embed the device into the slot after taking down the support and then fix by support.

1.5.1 安装方法

1.5.1 Installation method



图 1.2 ASD500 安装方法

Figure 1.2 Installation method of ASD500

1.5.2 开孔尺寸 (单位: 毫米)

1.5.2 Hole size (unit: mm)

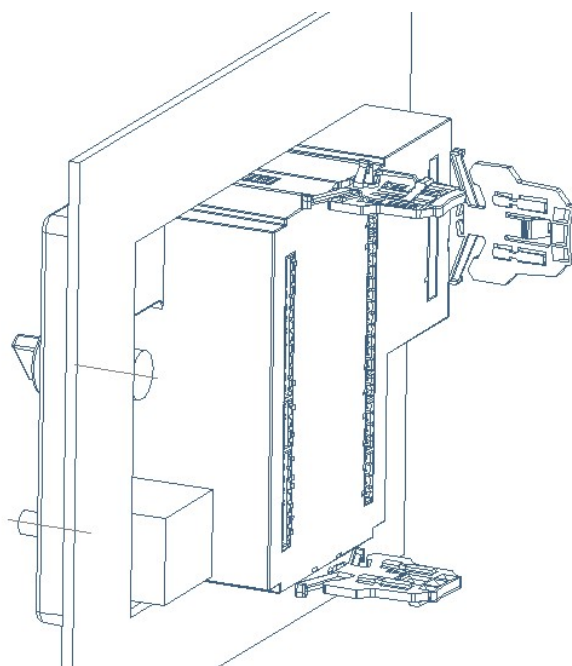

图 1.3 ASD500 开孔尺寸

Figure 1.3 Hole size diagram of ASD500

1.5.3 无线温度传感器的安装

1.5.3 Installation of wireless temperature transceiver

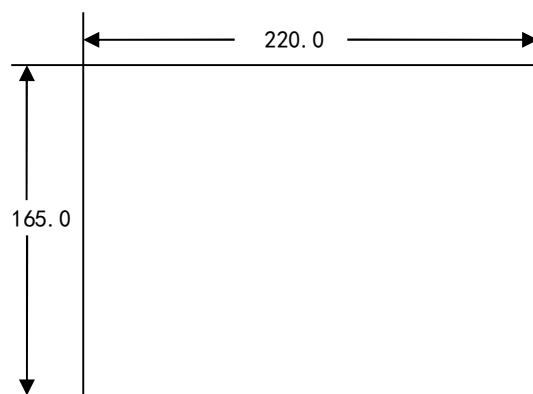
无线温度传感器共有多种型号，分别对应表带固定、扎带捆绑安装方式。

There are several types of wireless temperature sensors and mounting methods correspondingly, i.e. bolted type, strap-secured type, tied type and alloy chip fixed type.



图 1.4 表带式无线温度传感器 ATE200

Figure 1.4 Strap-secured wireless temperature sensor ATE200

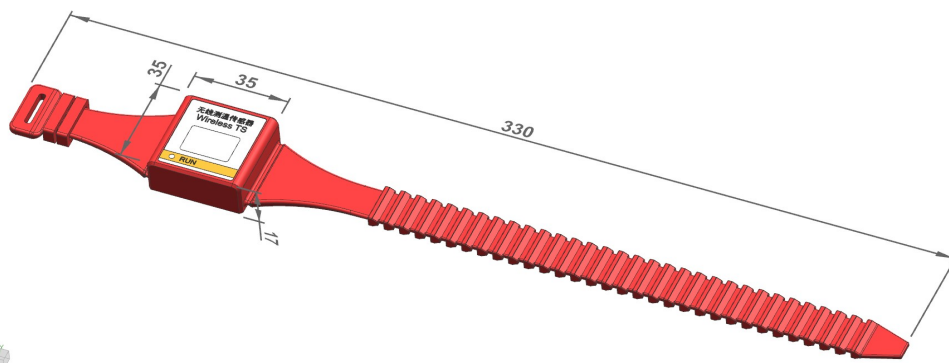

图 1.6 无源无线温度传感器 ATE400

Figure 1.6 Passive wireless temperature sensor ATE400

无源无线温度传感器结构说明:

passive temperature sensor structure introduction:

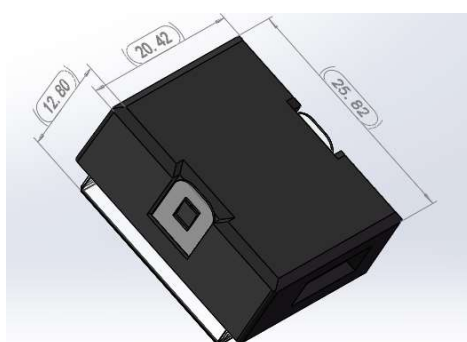
- 1 —— 温度传感器主体 The core of wireless temperature sensor ATE400
- 2 —— 合金底座，与温度探头接触 alloy bottom, touched with temperature probe
- 3 —— 锁扣，用于固定合金片 metal hasp, for fixing alloy chip
- 4 —— 取电合金片，用于感应取电 alloy chip, for CT-powered
- 5 —— 硅胶垫片，用于支撑合金片 silicone gasket, used to support the alloy chip
- 6 —— 合金片安装孔，用于安装合金片 alloy chip hole, used to install the alloy chip



图 1.7 ATE400 结构说明

Figure1.7 structure introduction of ATE400

1.5.4 注意事项

1.5.4 Precautions

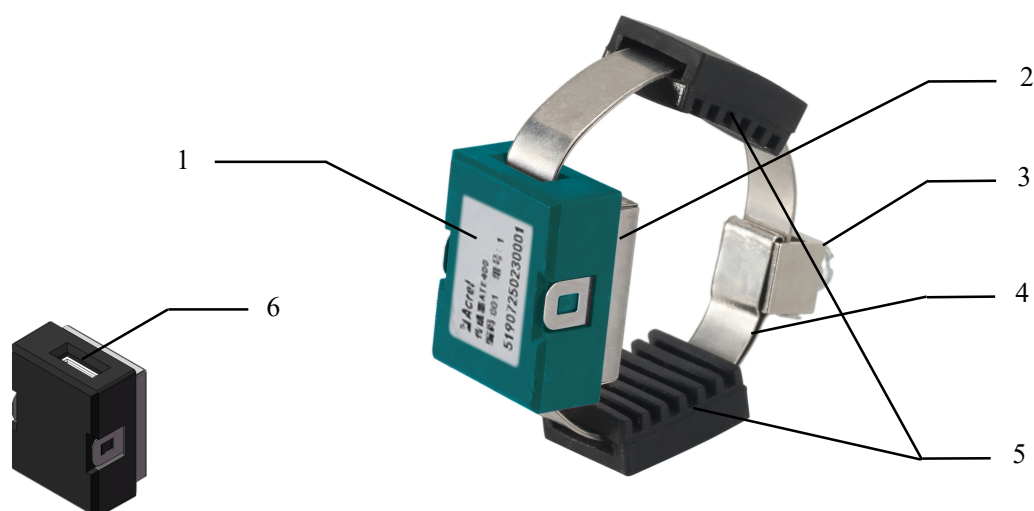
1) 请根据安装位置以及要求选择最合适的无线测温产品。

1) Please select the most suitable wireless temperature measurement product according to the installation location and requirements.

2) 所有传感器的安装，请严格按照说明书的安装说明。若出现因安装错误，导致安装附件不够，需由客户自行承担。

2) For the installation of all sensors, please strictly follow the instructions in the manual. If there is insufficient accessories due to installation errors, the customer shall bear the responsibility.

3) 无线测温下单前，需要有详细的配置方案，并在下单时填写**安科瑞无线测温确认表**！将配置方案及无线测温确认表一同交给内勤。

3) Before placing an order for wireless temperature measurement products, you need to have a detailed configuration plan, and fill in the **Acrel Wireless Temperature Measurement Confirmation Form** ! Then submit the plan and form to the back office.

1.6 接线方法

1.6 Wiring method

1.6.1 接线端子

1.6.1 Wiring terminal



图 1.10 ASD500 背面端子图

Figure 1.10 ASD500 back terminal diagram

1.6.2 典型接线图

1.6.2 Typical wiring diagram

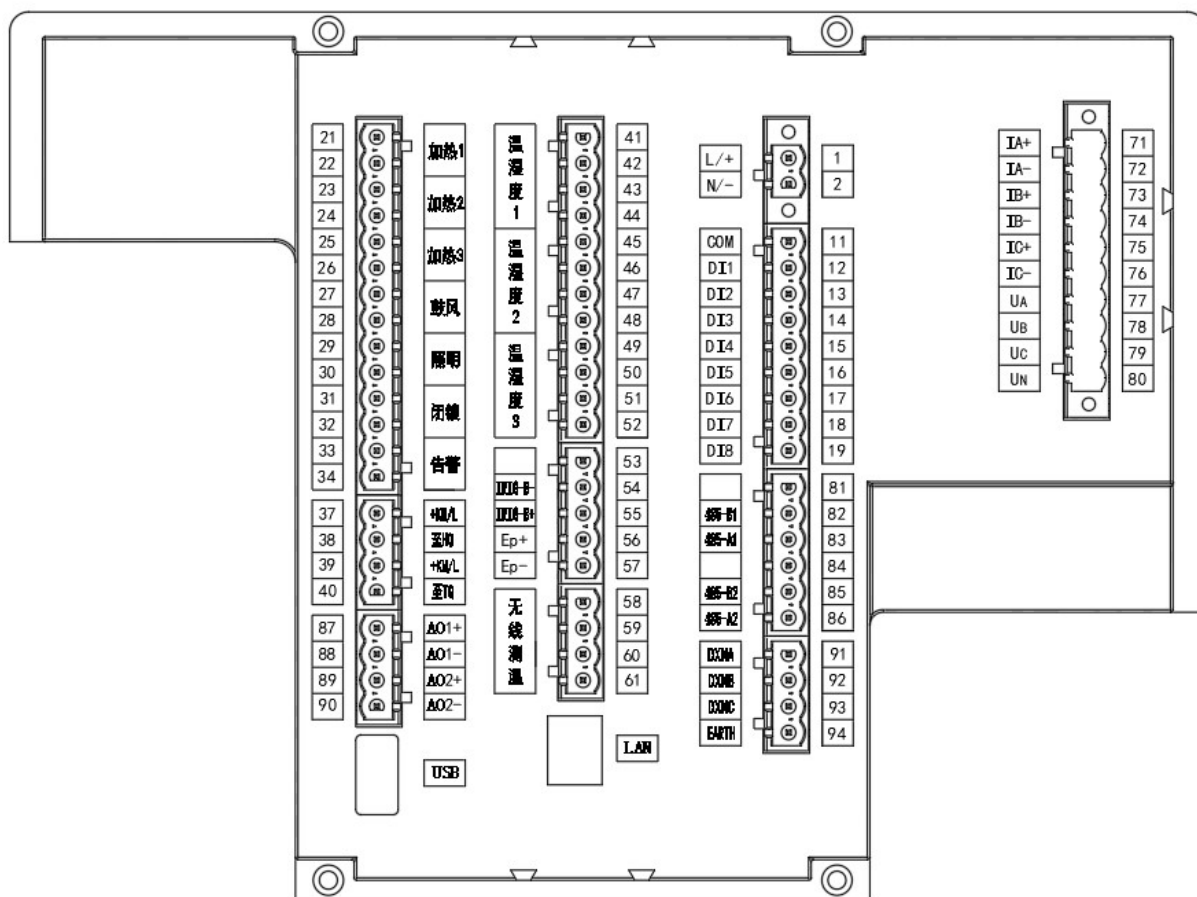

图 1.11 ASD 开关量输入回路典型接线图

Figure 1.11 Typical wiring diagram of ASD switch input circuit

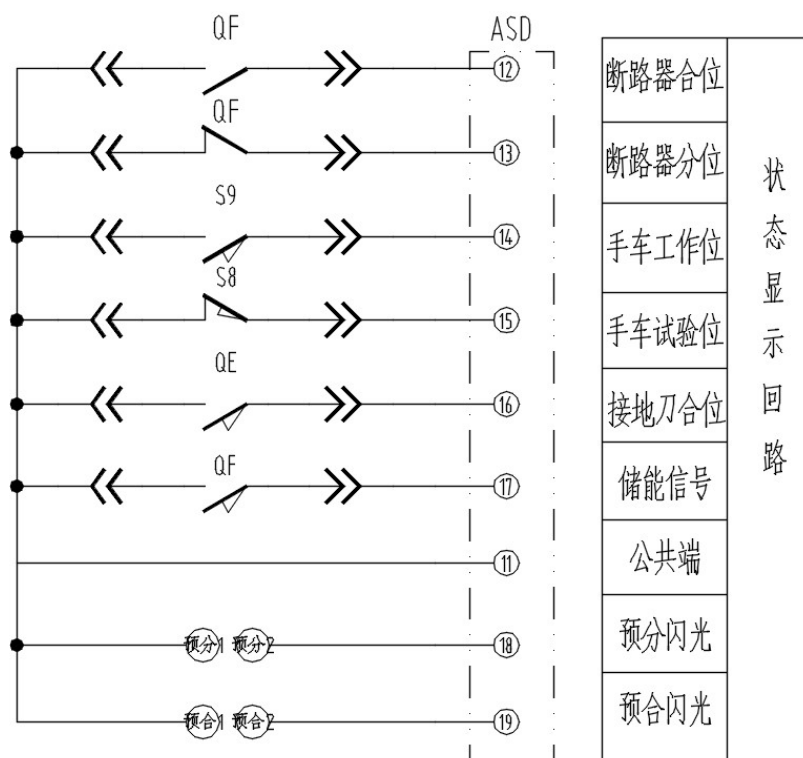

图 1.12 ASD 开关量输出、高压带电显示回路及传感器典型接线图

Figure 1.19 Typical wiring diagram of ASD switch output, HV live displaying circuit and sensor

2 产品操作指南

2 Product operation guide

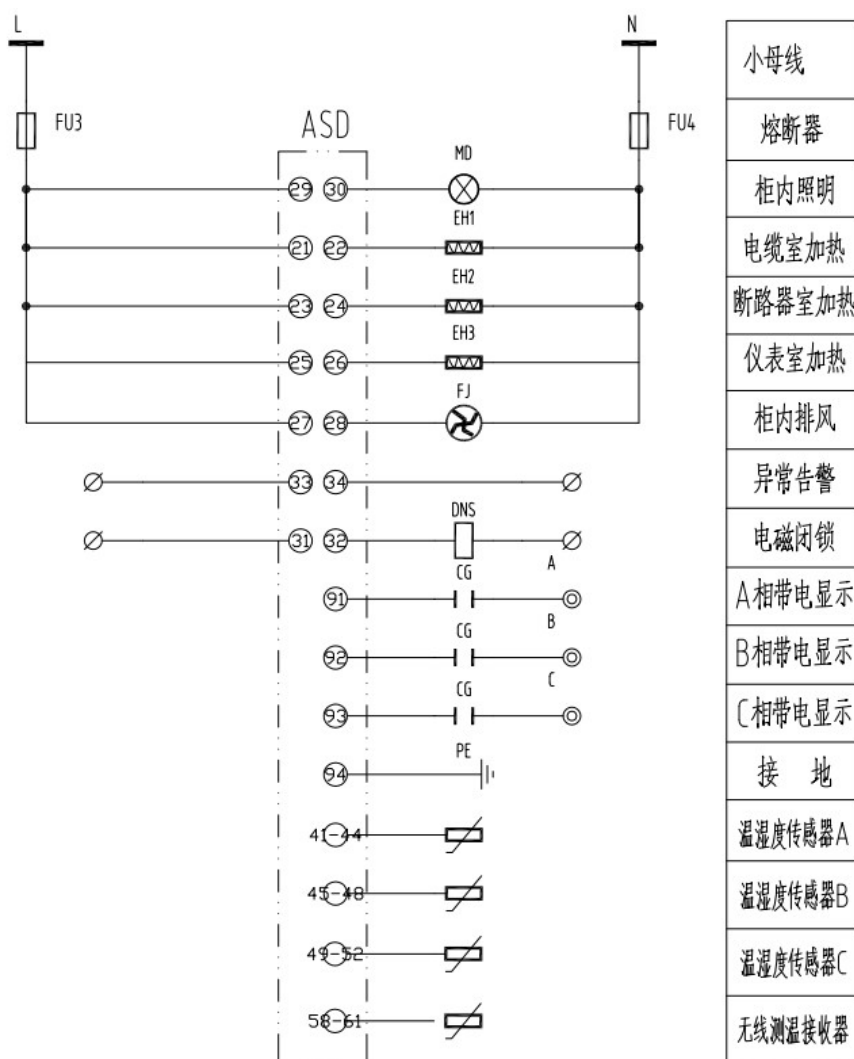
本操作说明主要针对 ASD500 型开关柜综合测控装置。

The operation instruction mainly aims at ASD500 switch cabinet integrated measuring and control device.

2.1 显示介绍

2.1 Display introduction



图 3.1 ASD500 前面板图

Figure 3.1 ASD500 front panel diagram

表 3 ASD500 前面板功能说明

Table 3 Function description of ASD500 front panel

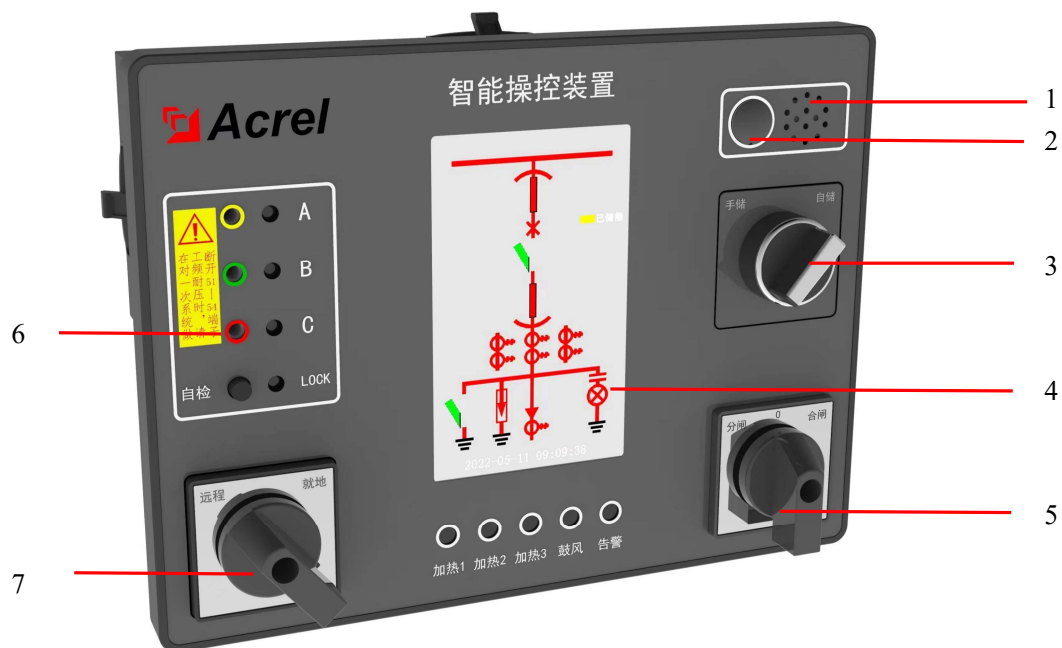
编号 No.	说明 Description
1	扬声器 speaker
2	人体感应探测口 Human body induction detection port
3	储能旋钮 Stored energy knob
4	液晶显示屏 LCD
5	分闸/合闸操作开关 Tripping/closing operating switch
6	高压带电显示及闭锁 HV live displaying and lock
7	远方/就地操作开关

	Remote/local operating switch
--	-------------------------------

2.2 操作介绍

2.2 Operation introduction

2.2.1 装置上电

2.2.1 Device power-on

接通符合要求的工作电源，装置即进入工作状态。

Connect the working power supply conforming to requirements and the device will enter working state.

2.2.2 动态模拟图

2.2.2 Dynamic mimetic diagram

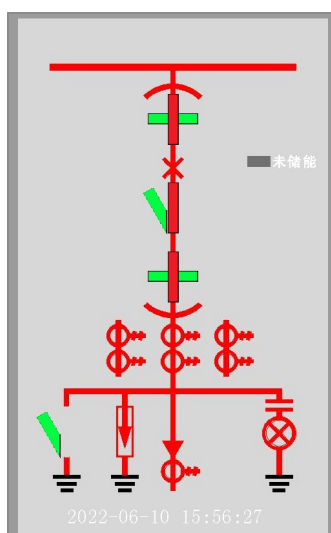

1) 断路器分、合闸指示

1) Breaker tripping/closing instructions

将断路器的分、合位置的辅助接点正确接入装置，装置上电正常工作后：

After the auxiliary contact of breaker tripping/closing position is correctly connected to device and the device is powered on for normal operation:

断路器处于合闸状态时，红色发光条 3 亮；

When the breaker is under close position, the red light bar 3 will be on;

断路器处于分闸状态时，绿色发光条 4 亮；

When the breaker is under open position, the green light bar 4 will be on;

2) 手车位置指示

2) Trolley position instructions:

将手车位置的辅助接点正确接入装置，装置上电正常工作后：

After the auxiliary contact of trolley position is correctly connected to device and the device is powered on for normal operation:

手车工作位置接点闭合时，红色发光条 1、5(上下两条)亮，指示小车位于工作位置；

When the operating position contact of trolley is closed, the red light bar 1、bar5 (upper and lower ones) will be on and it indicates that the trolley is under operating position;

手车试验位置接点闭合时，绿色发光条 2、6(上下两条)亮，指示小车位于试验位置。

When the testing position contact of trolley is closed, the green light bar 2、 bar 6 (upper and lower ones) will be on and it indicates that the trolley is under testing position.

手车不在工作或试验位时，红/绿发光条同时闪烁。

When the handcart is not in operation or test position, the red / green light-emitting strip flashes at the same time.

3) 接地开关位置指示

3) Earthing switch position instructions

将接地开关的辅助接点正确接入装置，装置上电正常工作后：

After the auxiliary contact of trolley position is correctly connected to device and the device is powered on for normal operation:

输入接点闭合时，红色发光条 9 亮，表示接地开关处于合闸状态；

When the input contact is closed, the red light bar 9 will be on and it indicates that the earthing switch is under close position;

输入接点断开时，绿色发光条 10 亮，表示接地开关处于分闸状态。

When the input contact is disconnected, the green light bar 10 will be on and it indicates that the earthing switch is under open position.

4) 弹簧储能指示

4) Spring energy storage instructions

将储能机构的辅助接点正确接入装置，装置上电正常工作后，输入接点闭合，指示灯 13 亮，表示已储能。

After the auxiliary contact of energy storage mechanism is correctly connected in the device and the device is powered on for normal operation, the input contact will be closed and the indicator light 13 will be on and it indicates that energy has been stored.

注：开关量与指示灯对应关系可根据用户需求灵活设定！

Note: The correspondence of switch quantity and indicator light can be flexibly set according to user needs.

2.2.3 高压带电显示及闭锁

2.2.3 HV live displaying and lock

装置的高压带电显示功能适用于 3.6-40.5kV/50Hz 系统，与相应电压等级的传感器配合使用，显示主回路的带电情况。若传感器为用户自行配置，须保证其对地短路输出电流大于 200 μ A。

The HV live displaying function of device is applicable to 3.6-40.5kV/50Hz system, which is used cooperatively with corresponding voltage classes to display the live condition of main circuit. If the sensor is allocated by the user itself, it must guarantee that the earthing short circuit output current shall be larger than 200 μ A.

在母线各相电压均小于额定电压的 15%时，强制闭锁处于“解锁”状态，前面板上“LOCK”指示灯不亮，“闭锁”接点闭合；母线任意相电压大于额定电压的 40%时，强制闭锁处于“闭锁”状态，“LOCK”指示灯亮，“闭锁”接点断开。

When the voltage of all phases of busbar is less than 15% of rated voltage, the forced lock is under “unlock” status and the “LOCK” indicator light on front panel will not be on and the “Lock” contact will be closed; when any phase voltage of busbar is larger than 40% of rated voltage, the forced lock is under “lock” status and “LOCK” indicator light will be on, the “lock” contact will be disconnected.

2.2.4 报警继电器输出

2.2.4 Alarm relay output

自动定值越限告警继电器输出包括：过压、欠压、过流、温控 1 超温、温控 2 超温、温控 3 超温、无线温度传感器组 1 高温、无线温度传感器组 2 高温、无线温度传感器组 3 高温、无线温度传感器组 4 高温。

The auto definite value threshold crossing alert relay output includes: overvoltage, undervoltage, over current, temperature control 1 over temperature, temperature control 2 over temperature, temperature control 2 over temperature, wireless temperature sensor group 1 high temperature, wireless temperature sensor group 4 high temperature.



注意：1.以上告警需将相应的控制字选择为“投入”才有效！

2. 发生加热回路断线及装置失电时，告警出口闭合。

Note: 1.It is valid only corresponding control word is selected as “input” .

2. When the heating circuit breaks and the device loses power, the alarm outlet is closed.

2.2.5 温湿度控制

2.2.5 Auto temperature and humidity control

采用数字式温湿度控制，当环境相对湿度 $\geq 85\%$ ，启动加热，当相对湿度 $\leq 77\%$ ，停止加热；当环境温度 $\geq 40^\circ\text{C}$ ，启动风扇鼓风，当温度 $\leq 35^\circ\text{C}$ ，停止鼓风。当环境温度 $\leq 5^\circ\text{C}$ ，启动加热，当环境温度 $\geq 13^\circ\text{C}$ ，停止加热。ASD500 可测量并采用 LCD 显示现场环境的温度和湿度，带有加热、鼓风控制接点，可根据需要，自行设定加热、除湿、鼓风的上下限。传感器及其相关的参数及控制接点关系如图 2.2 所示。

在“参数—>动作”界面可强制启动加热及鼓风。

Digital temperature and humidity control. When the environment relative humidity is $\geq 85\%$, start heating; when the relative humidity is $\leq 77\%$, stop heating; when the environment temperature is $\geq 40^\circ\text{C}$, start fan blast; when the temperature is $\leq 35^\circ\text{C}$, stop blasting. When the environment temperature is $\leq 5^\circ\text{C}$, start heating; when the environment temperature is $\geq 13^\circ\text{C}$, stop heating. ASD500 can measure and adopt LCD to display the temperature and humidity of site environment. With heating, blast control contact, the upper and lower limit of heating, dehumidification and blast can be set according to requirements. The sensor and related parameters and the relationship between control contact are shown in Figure 2.2.

In the "parameter -> action" interface, heating and blowing can be forcibly started.



图 2.2 温湿度控制关系

Figure 2.2 Temperature and humidity control relationship

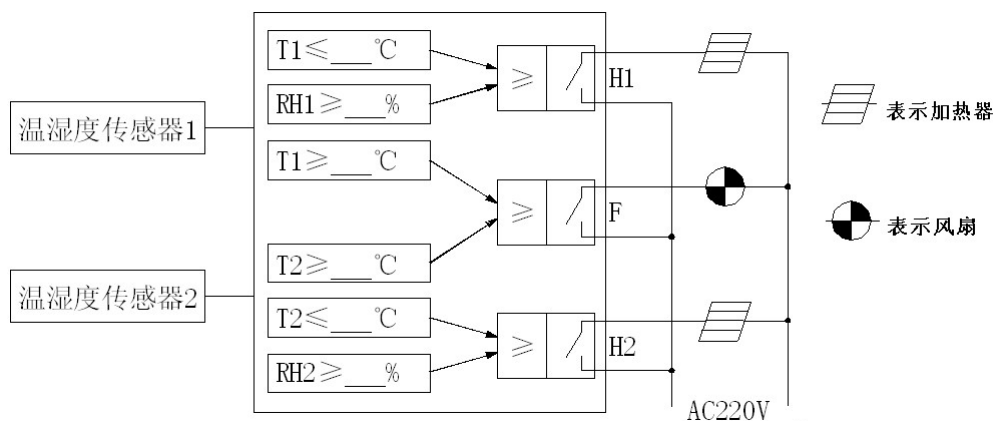

2.2.6 无线测温

2.2.6 Wireless temperature measurement

ASD500 可选无线测温功能，装置通过无线温度接收器和各无线温度传感器直接进行温度值的传输，并采用液晶显示各无线温度传感器所测温度。

ASD500 optional wireless temperature measurement functions. The device can directly transmit temperature values through wireless temperature receiver and all wireless temperature sensors and adopt LCD to display the temperature measured by all wireless temperature sensors.

ASD 主体与无线温度传感器的配对及校准（出厂已完成此工作，请勿随意进行此操作）：

Matching and calibration of ASD main body and wireless temperature sensor:(Factory set, Do not change it at will):

1) ASD 主体液晶操作进入“调试—>节温设置”下的节温设置菜单。

1) ASD main body LC operation enters the thermostat setting menu under “debugging

--->thermostat .

2) 输入对应无线温度传感器 ID 进行绑定，如查看标签为 TA1 的无线温度传感器的 ID，将此 ID 输入到节温 1A，输入完全部要配对传感器，按刷新键保存设置。

2) Enter the ID of the wireless temperature sensor corresponding to the wireless temperature sensor, such as the ID of the wireless temperature sensor with the tag TA1, enter this ID into the section temperature 1A, enter all the sensors to be matched, and press the refresh button to save the setting

3) ASD 主体液晶操作进入“调试—>节温校准”下的节温校准菜单。

3) ASD main body LC operation enters the thermostat calibration menu under “debugging --->thermostat.

4) 更改需校准的节温值为准确值，按刷新键进行校准。

4) Change the section temperature to be calibrated to the exact value, press the refresh key to calibrate.

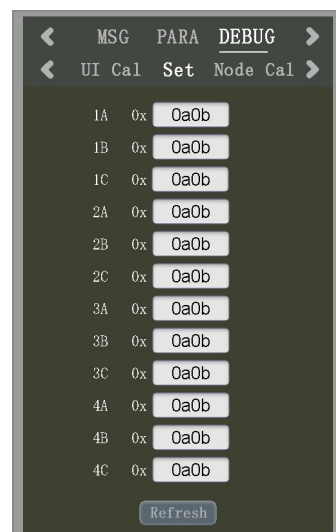
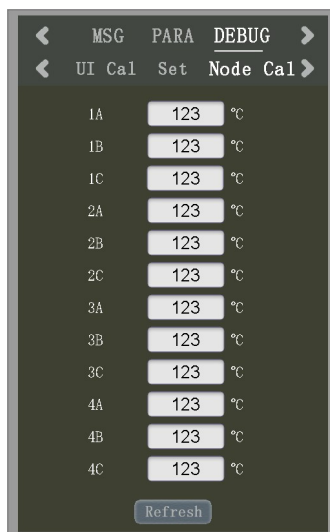
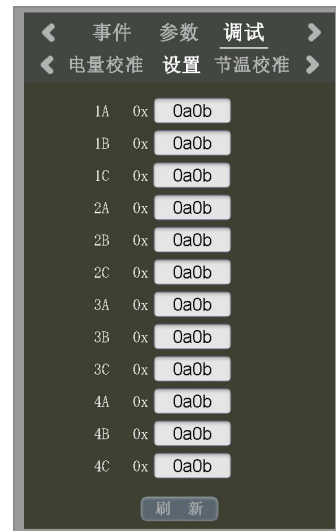
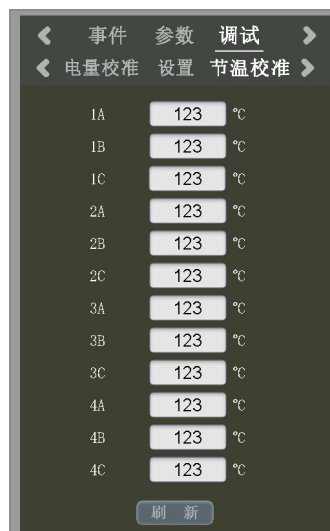

警告！ 出厂时包装箱内无线温度传感器与 ASD 主体已配对和校准！安装时不可以与其他 ASD 主体或无线温度传感器混用，无线温度传感器按其标签 A、B、C 分别对应安装到 A、B、C 相。

Warning! When it is delivered, the wireless temperature sensor in the packing case has already been matched with ASD main body and calibrated. When it is installed, it cannot be mixed with any other ASD main body or wireless temperature sensor. The wireless temperature sensor shall be respectively installed to A, B and C-phase according to its label A, B and C.

ASD 主体与无线温度传感器可按以下方法进行配套识别：

The ASD body and the wireless temperature sensor can be identified in the following ways:



ASD 标签

ASD Tag



ATE200 标签

ATE200 Tag



ATE400 标签

ATE400 Tag

例如左图为一台 ASD 主体的标签，如果此 ASD 配套的传感器为 ATE100/ATE100M/ATE200/ATE400，则传感器的标签的“组号”和 ASD 主体条码的最后 3 位数值一样。

For example, the left image is a label of an ASD body; if the sensor associated with the ASD is the ATE100/ATE100M/ATE200/ATE400, the “Group No.” of the tag of the sensor is the same as the last 3-bit value of the ASD body barcode.

2.2.7 智能语音提示

2.2.7 Intelligent voice prompt

2.2.7.1 智能语音防误提示共有三种方式可选择。

Three methods can be selected for intelligent voice error-preventing prompt.

方式一：断路器、接地开关处于合闸状态，若误将小车从试验位置推至工作位置，装置语音提示“请分断路器，请分接地开关”；断路器处于合闸状态，若误将小车从试验位置推至工作位置，装置语音提示“请分断路器”；接地开关处于合闸状态，若误将小车从试验位置推至工作位置，装置语音提示“请分接地开关”。

Method I: When the breaker and earthing switch are under close position, if the trolley is pushed to operating position from testing position by mistake, the device voice will prompt “please disconnect the breaker and earthing switch”; when the breaker is under open position, if the trolley is pushed to operating position from testing position by mistake, the device voice will prompt “please disconnect the breaker”; when the earthing switch is under open position, if the trolley is pushed to operating position from testing position by mistake, the device will voice prompt “please disconnect the earthing switch”.

方式二：断路器、接地开关处于合闸状态，若误将小车从试验位置/工作位置推开，装置语音提示“请分断路器，请分接地开关”；断路器处于合闸状态，若误将小车从试验位置/工作位置推开，装置语音提示“请分断路器”；接地开关处于合闸状态，若误将小车从试验位置/工作位置推开，装置语音提示“请分接地开关”。

Method II: When the breaker and earthing switch are under close position, if the trolley is pushed away from testing position/operating position by mistake, the device will voice prompt “please disconnect the breaker and earthing switch”; when the breaker is under close position, if the trolley is pushed away from testing position/operating position by mistake, the device will voice prompt “please disconnect the breaker”; when the earthing switch is under close position, if the trolley is pushed away from testing position/operating position by mistake, the device will voice prompt “please disconnect the earthing switch”.

方式三：断路器处于合闸状态，若误将小车从试验位置/工作位置推开，装置语音提示“请分断路器”。

Method III: When the breaker is under close position, if the trolley is pushed away from testing position/operating position by mistake, the device will voice prompt “please disconnect the breaker”.

2.7.7.2 带电语音提示

2.7.7.2 live voice prompt

当装置监测到高压回路带电时，装置通过感应到周围红外场的变化感知有人接近，会进行高压带电语音安全提示，此功能可在“参数—>语音”菜单内开启或关闭。

When the device detects that the high-voltage circuit is charged, the device senses someone approaching by sensing the change of the surrounding infrared field, and will give a high-voltage charged

voice safety prompt. This function can be turned on or off in the "parameters -> voice" menu



2.2.8 柜内照明功能

2.2.8 Cabinet lighting function

在装置参数菜单栏的动作界面，按至 on,强制打开柜内照明，可修改照明时间；按至 off，将关闭柜内照明。

LCD 背光自动控制开启时（背光延时设置不为 0），当有人接近装置时，装置通过感应到周围红外场的变化感知有人接近，自动打开柜内照明及液晶背光；人离开装置设定的时间后，自动关闭柜内照明和液晶背光。

In the action interface of the device parameter menu bar, press to on to force the lighting in the cabinet to be turned on, and the lighting time can be modified; Press to off to turn off the lighting in the cabinet.

When the LCD backlight automatic control is turned on (the backlight delay setting is not 0), when someone approaches the device, the device senses someone approaching by sensing the change of the surrounding infrared field, and automatically turns on the lighting in the cabinet and the LCD backlight; After the person leaves the device for the set time, the lighting in the cabinet and LCD backlight will be automatically turned off

2.2.10 电力参数测量

2.2.10 Electric power parameter measurement

ASD500 型开关柜综合测控装置可以测量主回路的电流、电压、有功功率、功率因数、电能等电力参数，可在装置“电量”菜单中查看。无功功率、视在功率等可以通过通讯口读出。

ASD500 switch cabinet integrated measuring and control device can measure the current, voltage, active power, power factor, electric energy and other electric parameters of main circuit and check in the

“electric quantity” menu of device. the active power, apparent power can be read out through communication port.

电参数的显示均为一次侧值，用户需选择正确的信号接入方式及 CT、PT 变比，以便正确显示测量值。

The display of electric parameter is all primary side value and the user shall select correct signal access way and CT, PT no-load voltage ratio to correctly display the measured value.

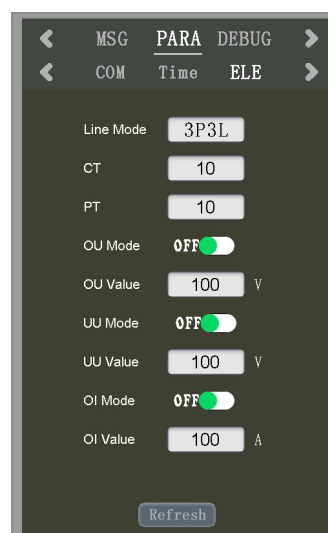
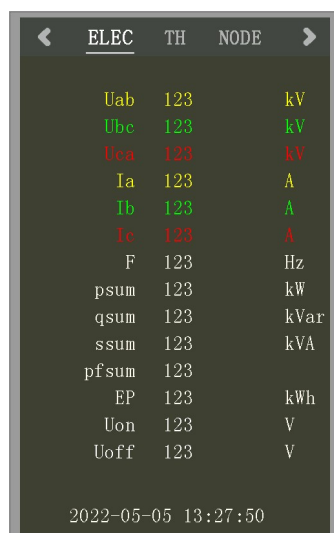



图 2.4 接线方式

Figure 2.4 Wiring mode

2.2.11 带电显示自检

2.2.11 Self-inspection of live displaying

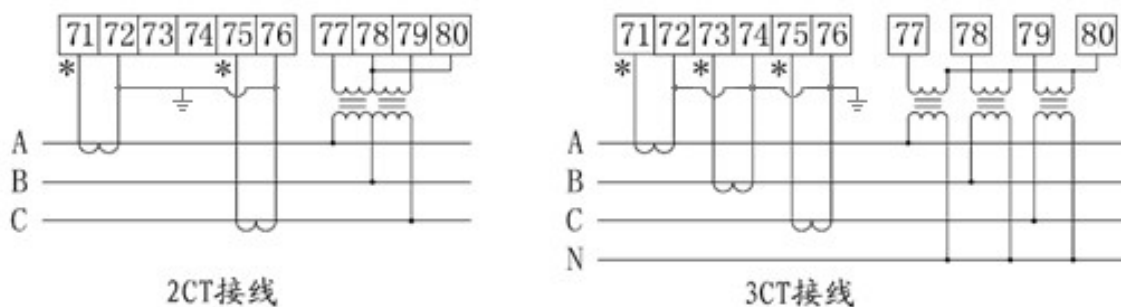
ASD500 开关柜综合测控装置具有带电显示自检功能，可在装置面板的下方按键进行自检操作。按下按钮，对应指示灯亮并保持几秒钟，闭锁继电器端子断开（闭锁继电器端子不工作时处于常闭状态），说明带电显示灯正常。

ASD500 switch cabinet integrated measuring and control device has live displaying self-inspection function, which can take self-inspection operation through the key under device panel. Press the button and corresponding LED will be lit for a few seconds and the lock relay will be open (it is normally closed when lock relay terminal is not working) and it indicates that the live displaying light is normal.

2.2.12 核相功能

2.2.12 Nuclear phase function

ASD500 开关柜综合测控装置具有带电显示核相功能，在装置接入高压信号经带电显示传感器后的信号后，可通过外接核相器接入装置的核相孔中，进行核相操作。该核相功能适用于市面上大多数的核相器（门槛电压 $\geq 60V$ ）。

ASD 500 switch cabinet integrated measuring and control device has live displaying nuclear phase function. After connecting the signal of live displaying sensor through HV signal, it can take nuclear phase operation by connecting the nuclear phase into the nuclear phase hole of device. This nuclear phase function is applicable to great majority nuclear phase testers in the market (with threshold voltage $\geq 60V$).

3 通讯指南

3 Communication guide

在本章主要讲述如何利用软件通过通讯口来操控该系列仪表。本章内容的掌握需要您具有

MODBUS 协议的知识储备并且通读了本册其他章节所有内容，对本产品功能和应用概念有较全面的了解。

In this chapter, it mainly introduces how to use software to control this series of instrument through communication port. To master this chapter, you must possess the knowledge reserve of MODBUS and have read all the contents in other chapters and have comprehensive understanding to the function and application concept of the product.

本章内容包括：通讯应用格式详解，本机的应用细节及参量地址表。

The content of the chapter includes: detailed explanation of communication application format, application details and parameter address table.

3.1 通讯格式详解

3.1 Detailed explanation of communication format

本节所举实例将尽可能的使用如下表所示的格式，数据为十六进制。

The format shown in table below will be used as much as possible for the examples in this section and the data is hexadecimal.

3.1.1 读取数据（功能码 03H/04H）

3.1.1 Reading data (function code 03H/04H)

此功能允许用户获得设备采集与记录的数据及系统参数。主机一次请求的数据个数没有限制，但不能超出定义的地址范围。

The function allows user to obtain the data and system parameters collected and recorded by equipment. There is no restriction to the data number primarily requested by main engine, but it shall not exceed the defined address scope.

例如，主机发送查询数据帧：

For example, main engine will send the query data frame:

地址 Addr	功能码 Fun	起始地址 Start Addr		寄存器数量 Register number		CRC16 校验码 CRC 16 check code	
		高 High	低 Low	高 High	低 Low	高 High	低 Low
01H	03H	00H	30H	00H	03H	05H	C4H

装置返回响应数据帧：

The device will return the response data frame:

地址 Addr	功能码 Fun	字节数 byte	数据 1 Date 1		数据 2 Date 2		数据 3 Date 3		CRC16 校验码 CRC 16 check code	
			高 High	低 Low	高 High	低 Low	高 High	低 Low	高 High	低 Low
01H	03H	06H	00H	00H	00H	00H	00H	00H	21H	75H

3.1.2 预置单个寄存器（功能码 06H）

3.1.2 Preset single register (function code 06H)

此功能码允许用户改变单个寄存器的内容，可通过此功能码将工作参数写入装置。

The function code allows user to change the content of single register and operating parameters can be written into device through the function code.

例如，主机发送：

For example, the main engine sends:

地址 Addr	功能码 Fun	寄存器地址 Register address		预置值 Preset value		CRC16 校验码 CRC 16 check code	
		高 High	低 Low	高 High	低 Low	高 High	低 Low
01H	06H	00H	03H	03H	E8H	74H	79H

装置返回响应数据帧：

The device returns to response data frame:

地址 Addr	功能码 Fun	寄存器地址 Register address		预置值 Preset value		CRC16 校验码 CRC 16 check code	
		高 High	低 Low	高 High	低 Low	高 High	低 Low
01H	06H	00H	03H	03H	E8H	74H	79H

3.1.3 预置多个寄存器（功能码 10H）

3.1.3 Preset several registers (function code 10H)

此功能码允许用户改变多个寄存器的内容，可通过此功能码将工作参数写入装置。

The function code allows user to change the content of several registers and operating parameters can be written into device through the function code.

例如，主机发送：

For example, the main engine sends:

地址 Addr	功能码 Fun	起始地址 Start Addr		寄存器数 Register number		字节数 byte	预置值 1 Preset value 1		预置值 2 Preset value 1		CRC16	
		高 High	低 Low	高 High	低 Low		高 High	低 Low	高 High	低 Low	高 High	低 Low
01H	10H	00H	03H	00H	02H	04H	00H	28H	00H	64H	59H	32H

装置返回响应数据帧：

The device returns to response data frame:

地址 Addr	功能码 Fun	起始地址 Start Addr		寄存器数量 Register number		CRC16 校验码 CRC 16 check code	
		高字节	低字节	高字节	低字节	高字节	低字节

		High byte	Low byte	High byte	Low byte	High byte	Low byte
01H	10H	00H	03H	00H	02H	B1H	C8H

3.2 参量地址表

3.2 Parameter address table

地址 Addr	参数 Parameter	属性 Read/ Write	数值范围 Data range	数据类型 Data Type
0000H	通讯地址 Communication Addr	R/W	1~247	Word
0001H	通讯波特率 Communication Baud rate	R/W	2400、4800、9600、19200	Word
0002H	电量输入方式 Electric parameter Input mode	R/W	0: 3P3L 1:3P4L	Word
0003H	电流变比 CT transformation	R/W	0.1~999.9 (x10)	Word
0004H	电压变比 PT transformation ratio	R/W	0.1~999.9 (x10)	Word
0005H	控制字 Control word	R/W	继电器报警控制字: 0-off 1-on bit0:过压 bit1:欠压 bit2:过载 bit3-温湿控 1 bit4-温湿控 2 bit5:语音提示 bit8~bit11 节温组 1~4 bit12:分合闸电压检测开启 Alarm relay control word:0-off, 1-on bit0:Over voltage; bit1:under voltage; bit2:over load; bit3-Temp./humidity control 1; bit4-Temp./humidity control 2; bit5:Voice alert; bit8~bit11: The section temperature group 1to4; bit12: tripping circuit and closing circuit control voltage measurement function enabled.	Word
0006H	通道 A 低温设定值 (加热 I) Channel A Lo.temp.setting (heating I)	R/W	-45~125℃	Word
0007H	通道 A 高温设定值 Channel A Hi.temp.setting	R/W	0~125℃	Word

0008H	通道 A 超温设定值 (鼓风) Channel A over-temp setting(air blowing)	R/W	0~125℃	Word
0009H	通道 A 高湿度设定值 (加热 I) Channel A Hi humidity setting(heating I)	R/W	10~99%	Word
000AH	通道 B 低温设定值 (加热 II) Channel B Lo.temp. setting(heating II)	R/W	-45~125℃	Word
000BH	通道 B 高温设定值 Channel B Hi.temp.setting	R/W	0~125℃	Word
000CH	通道 B 超温设定值 (鼓风) Channel B over-temp setting(air blowing)	R/W	0~125℃	Word
000DH	通道 B 高温设定值 (加热 II) Channel B Hi.temp.setting (heating II)	R/W	10~99%	Word
000EH	过压定值 Overvoltage setting	R/W	二次侧 1~999V Secondary side 1~999V	Word
000FH	欠压定值 Undervoltage setting	R/W	二次侧 1~999V Secondary side 1~999V	Word
0010H	过流定值 Overcurrent setting	R/W	二次侧 0~99.9A (x10) Secondary side 0~99.9A (x10)	Word
0011H	液晶背光自动关闭 时间 Liquid crystal back light Automatic closed time	R/W	0-999s, 0—背光常亮 0-999s, 0: Always bright backlight	Word
0012H	继电器输出 Relay output	R/W	bit0-4 对应: 加热 I、加热 II、鼓风、告警、照明 Bit0-bit4: Heating I,heating II,air blowing,alarming,lighting	Word
0013H	开关量输入 Switching input	R	Bit0-bit7 对应 DI1-DI8 Bit0-bit7 corresponding DI1-DI8	Word

0014H	定值类报警状态 Value class alarm status	R	<p>0-未告警 1-告警</p> <p>bit0-bit3 对应: 通道 A 低温、通道 A 高温、通道 A 超温、通道 A 高湿</p> <p>bit4-bit7 对应: 通道 B 低温、通道 B 高温、通道 B 超温、通道 B 高湿</p> <p>bit8:过压 bit9:欠压 bit10:过载</p> <p>bit11-bit12 对应: 第一路测温故障、第二路测温故障</p> <p>bit13-bit14 对应: 第一路加热器故障 第二路加热器故障</p> <p>0-no alarm,1-alarmed.</p> <p>Bit0-bit3 corresponding: Channel A Lo.temp,Channel A Hi.temp,Channel A over temp,Channel A Hi humidity</p> <p>Bit4-bit7 corresponding: Channel B Lo.temp,Channel B Hi.temp,Channel B over temp,Channel B Hi humidity</p> <p>Bit8:over voltage;Bit9:under voltage; Bit10:over load</p> <p>Bit11-bit12 corresponding: 1nd temperature sensor failure, 2nd temperature sensor failure</p> <p>Bit13-bit14 corresponding: 1nd heating circuit fault alarm, 2nd heating circuit fault alarm</p>	Word
0015H	无线温度传感器高温报警状态 Wirless temperature sensor Hi.temp. alarm status	R	<p>0: 未报警 1: 已报警</p> <p>bit0~bit11:节点 1A~4C 高温</p> <p>0-no alarm,1-alarmed.</p> <p>Bit0-bit 11 :</p> <p>Section temperature 1A~ Section temperature 4C sensor Hi.temp.</p>	Word
0016H	无线温度传感器超温报警状态 Wireless temperature sensor over temperature alarm status	R	<p>0: 未报警 1: 已报警</p> <p>bit0~bit11:节点 1A~4C 传感器超温</p> <p>0-no alarm,1-alarmed.</p> <p>Bit0-bit 11 :</p> <p>Section temperature 1A~ Section temperature 4C sensor over temperature.</p>	Word
0017H	——	R/W	——	
0018H	年份 Year	R/W	<p>10~99 (对应 2010~2099)</p> <p>10~99 corresponding: 2010~2099</p>	Word
0019H	月份 Month	R/W	1~12	Word
001AH	高位: 日 High: Day	R/W	1~31	Word
	低位: 时 Low: Hour	R/W	0~23	Word

001BH	高位: 分 High: Minute	R/W	0~59	Word
	低位: 秒 Low: Second	R/W	0~59	Word
001CH	无线温度传感器组 1 高温定值 Wireless temperature sensor group 1 high temperature setting	R/W	0~125℃	Word
001DH	无线温度传感器组 2 高温定值 Wireless temperature sensor group 2 high temperature setting	R/W	0~125℃	Word
001EH	无线温度传感器组 3 高温定值 Wireless temperature sensor group 3 high temperature setting	R/W	0~125℃	Word
001FH	无线温度传感器组 4 高温定值 Wireless temperature sensor group 4 high temperature setting	R/W	0~125℃	Word
0020~0022H	1A 1B 1C 温度值 1A 1B 1C temperature value	R	0~125.0℃ (x10)	Word
0023~0025H	2A 2B 2C 温度值 2A 2B 2C temperature value	R	0~125.0℃ (x10)	Word
0026~0028H	3A 3B 3C 温度值 3A 3B 3C temperature value	R	0~125.0℃ (x10)	Word
0029~002BH	4A 4B 4C 温度值 4A 4B 4C temperature value	R	0~125.0℃ (x10)	Word
002CH	通道 A 温度值 Channel A temperature value	R	-45.0~125.0℃ (x10)	Word
002DH	通道 A 湿度值 Channel A humidity value	R	10.0~99.0% (x10)	Word
002EH	通道 B 温度值	R	-45.0~125.0℃ (x10)	Word

	Channel B temperature value			
002FH	通道 B 湿度值 Channel B humidity value	R	10.0~99.0%(x10)	Word
0030H	相电压 UA Phase voltage UA	R	一次侧: 0~6553.5 kV (x10) Primary side: 0~6553.5 kV (x10)	Word
0031H	相电压 UB Phase voltage UB	R	一次侧: 0~6553.5 kV (x10) Primary side: 0~6553.5 kV (x10)	Word
0032H	相电压 UC Phase voltage UC	R	一次侧: 0~6553.5 kV (x10) Primary side: 0~6553.5 kV (x10)	Word
0033H	线电压 UAB Line voltage UAB	R	一次侧: 0~6553.5 kV (x10) Primary side: 0~6553.5 kV (x10)	Word
0034H	线电压 UBC Line voltage UBC	R	一次侧: 0~6553.5 kV (x10) Primary side: 0~6553.5 kV (x10)	Word
0035H	线电压 UAC Line voltage UAC	R	一次侧: 0~6553.5 kV (x10) Primary side: 0~6553.5 kV (x10)	Word
0036H	IA	R	一次侧: 0~6553.5 A (x10) Primary side: 0~6553.5 kV (x10)	Word
0037H	IB	R	一次侧: 0~6553.5 A (x10) Primary side: 0~6553.5 kV (x10)	Word
0038H	IC	R	一次侧: 0~6553.5 A (x10) Primary side: 0~6553.5 kV (x10)	Word
0039H	保留 Reserved	R	保留 Reserved	
003AH-003B H	PA	R	一次侧: 0~6553.5kW Primary side: 0~6553.5kW	float
003CH-003D H	PB	R	一次侧: 0~6553.5kW Primary side: 0~6553.5kW	float
003EH-003F H	PC	R	一次侧: 0~6553.5kW Primary side: 0~6553.5kW	float
0040H-0041 H	Psum	R	一次侧: 0~6553.5kW Primary side: 0~6553.5kW	float
0042H-0043 H	QA	R	一次侧: 0~6553.5kvar Primary side: 0~6553.5kvar	float
0044H-0045 H	QB	R	一次侧: 0~6553.5kvar Primary side: 0~6553.5kvar	float
0046H-0047 H	QC	R	一次侧: 0~6553.5kvar Primary side: 0~6553.5kvar	float
0048H-0049 H	Qsum	R	一次侧: 0~6553.5kvar Primary side: 0~6553.5kvar	float
004AH-004B H	PFA	R	0.0~1.0	float

004CH-004D H	PFB	R	0.0~1.0	float
004EH-004F H	PFC	R	0.0~1.0	float
0050H-0051 H	Pfsum	R	0.0~1.0	float
0052H-0053 H	SA	R	一次侧: 0~6553.5kVA Primary side: 0~6553.5kVA	float
0054H-0055 H	SB	R	一次侧: 0~6553.5kVA Primary side: 0~6553.5kVA	float
0056H-0057 H	SC	R	一次侧: 0~6553.5kVA Primary side: 0~6553.5kVA	float
0058H-0059 H	Ssum	R	一次侧: 0~6553.5kVA Primary side: 0~6553.5kVA	float
005AH-005B H	Freq	R	45.0~65.0Hz	float
005CH-005D H	电能 Electrical energy	R	一次侧: 0.0~99999999.99kWh Primary side: 0.0~99999999.99kWh	float
005EH	——	R/W	——	
005FH	通道A低温报警返回 值设定 Low temperature alarm return value of Channel A	R/W	-45~125℃	Word
0060H	通道A高温报警返回 值设定 High temperature alarm return value of Channel A	R/W	0~125℃	Word
0061H	通道A超温报警返回 值设定 Over temperature alarm return value of Channel A	R/W	0~125℃	Word
0062H	通道A高湿报警返回 值设定 High humidity alarm return value of Channel A	R/W	10~99%	Word
0063H	通道B低温报警返回 值设定 Low temperature alarm return value of	R/W	-45~125℃	Word

	Channel B			
0064H	通道B 高温报警返回值设定 High temperature alarm return value of Channel B	R/W	0~125℃	Word
0065H	通道B 超温报警返回值设定 Over temperature alarm return value of Channel B	R/W	0~125℃	Word
0066H	通道B 高湿报警返回值设定 High humidity alarm return value of Channel B	R/W	10~99%	Word
0067H-0069H	——	R/W	——	
006AH	强制加热时间 Manual heating time	R/W	0~120min 0: 不加热 0~120min 0: Manual heating not performed	
006BH	通道C 低温设定值(加热I) Channel C Lo.temp. setting(heating I)	R/W	-45~125℃	
006CH	通道C 高温设定值 Channel A Hi.temp. setting	R/W	0~125℃	
006DH	通道C 超温设定值(鼓风) Channel C over-temp setting(air blowing)	R/W	0~125℃	
006EH	通道C 高湿设定值(加热I) Channel C Hi humidity setting(heating I)	R/W	10~99%	
006FH	通道C 低温报警返回值设定 Low temperature alarm return value of Channel C	R/W	0~99.9%	
0070H	通道C 高温报警返回值设定	R/W	0~99.9%	

	High humidity alarm return value of Channel C			
0071H	通道 C 超温报警返回值设定 Over temperature alarm return value of Channel C	R/W	0~99.9%	
0072H	通道 C 高湿报警返回值设定 High temperature alarm return value of Channel C	R/W	0~99.9%	
0073H	无线温度传感器组 1 超温定值 Wireless temperature sensor group 1 over temperature setting	R/W	0~125℃	Word
0074H	无线温度传感器组 2 超温定值 Wireless temperature sensor group 2 over temperature setting	R/W	0~125℃	Word
0075H	无线温度传感器组 3 超温定值 Wireless temperature sensor group 3 over temperature setting	R/W	0~125℃	Word
0076H	无线温度传感器组 4 超温定值 Wireless temperature sensor group 4 over temperature setting	R/W	0~125℃	Word
0077H	无线测温传感器组 1 超温返回值 Wireless temperature sensor group 1 over temperature return value	R/W	0~125℃	
0078H	无线测温传感器组 2 超温返回值 Wireless temperature sensor group 2 over	R/W	0~125℃	

	temperature return value			
0079H	无线测温传感器组 3 超温返回值 Wireless temperature sensor group 3 over temperature return value	R/W	0~125℃	
007AH	无线测温传感器组 4 超温返回值 Wireless temperature sensor group 4 over temperature return value	R/W	0~125℃	
007BH	定值类报警状态 2 Constant value alarm state 2	R	0-未告警 1-告警 bit0-bit3 对应: 通道 C 低温、通道 C 高温、通道 C 超温、通道 C 高湿 bit8-bit11 对应: 第三路测温故障、保留(第四路测温故障) 保留(第三路加热器故障) 保留(第四路加热器故障) 0-no alarm 1-alarm bit0-bit3 corresponding: channel C low temperature, channel C high temperature, channel C over temperature, channel C high humidity Bit8-bit11 corresponding: the third circuit temperature measurement fault, reservation (the fourth circuit temperature measurement fault) reservation (the third circuit heater fault) reservation (the fourth circuit heater fault)	
007CH	通道 C 温度值 Channel C temperature value	R	-45.0~125.0℃	
007DH	通道 C 湿度值 Channel C humidity value	R	10.0~99.0%	
007EH-0091H	保留 Reserved	R	保留 Reserved	
200H	工作语言: Language:	R/W	0: 中文 1: 英文 0: Chine 1: English	Word
201H	密码 1	R/W	0~9999	Word

	Password 1			
202H	密码 2 Password 2	R/W	0~9999	Word
203H	轮询时间 Polling time	R/W	0~9999s 0: 不轮询 0~9999s 0: no poll	Word
204H	通讯数据位 Communication data bits	R/W	8~9	Word
205H	通讯停止位 Communication stop bit	R/W	0~2: 0: 1 停止位 1: 1.5 停止位 2: 2 停止位 0~2: 0: 1 stop bit 1: 1.5 stop bit 2: 2 stop bit	Word
206H	通讯奇偶校验位 parity checkbit	R/W	0~2: 0: 无奇偶校验 1: 奇校验 2: 偶校验 0~2: 0: No parity 1: Odd parity 2: Even parity	Word
207H-20AH	——	R/W	——	
20BH	无线测温传感器组 1 高温返回值 Wireless temperature sensor group 1 High temperature return value	R/W	0~125℃	Word
20CH	无线测温传感器组 2 返回值 Wireless temperature sensor group 2 High temperature return value	R/W	0~125℃	Word
20DH	无线测温传感器组 3 返回值 Wireless temperature sensor group 3 High temperature return value	R/W	0~125℃	Word
20EH	无线测温传感器组 4 返回值 Wireless temperature sensor group 4 High temperature return value	R/W	0~125℃	Word
20FH-21AH	——	R/W	——	
21BH	合闸电压 closing circuit control voltage	R	0~6553.5V (*10)	Word
21CH	分闸电压	R	0~6553.5V (*10)	Word

	tripping circuit control voltage			
21DH	断路器分合次数 CB tripping and closing numbers	R	0~65535	Word
21EH	分合闸电压报警 Tripping/closing control voltage alarm	R	1:分闸过压 2:合闸过压 1: over voltage alarm of tripping control voltage 2: over voltage alarm of closing control voltage	Word
21FH-237H	——	R	——	Word
300H	通讯 2 地址 Communication 2 address	R/W	1~247	Word
301H	通讯 2 波特率 Communication 2 baud rate	R/W	2400、4800、9600、19200	Word
302H	通讯 2 数据位 Communication 2 data bits	R/W	8~9	Word
303H	通讯 2 停止位 Communication 2 stop bit	R/W	0~2: 0: 1 停止位 1: 1.5 停止位 2: 2 停止位	Word
304H	通讯 2 奇偶校验位 Communication 2 parity bit	R/W	0~2: 0: 无奇偶校验 1: 奇校验 2: 偶校验	Word
305H	——	R/W	——	
306H	变送 1 参数选择 Transmission 1 Parameter Selection	R/W		
	变送 1 输出类型 Transmitter 1 output type	R/W	0-3: 0: 0-20mA 1: 4-20mA 2: 0-5V 3: 0-10V 4: 1-5V	
307H	变送 1 高点 Transmission 1 high point	R/W	0-9999	
308H	变送 1 低点 Transmitter 1 low point	R/W	0-9999	
309H	变送 2 参数选择 Transmission 2	R/W		

	parameter selection			
	变送 2 输出类型 Transmitter 2 output type	R/W	0-3: 0: 0-20mA 1: 4-20mA 2: 0-5V 3: 0-10V 4: 1-5V	
30AH	变送 2 高点 Transmission 2 high point	R/W	0-9999	
30BH	变送 2 低点 Transmission 2 low point	R/W	0-9999	
30CH-30DH	IP 地址[4] IP address [4]	R/W		byte
30EH-310H	MAC 地址[6] MAC address [6]	R/W		byte
311H-312H	子网掩码[4] Subnet mask [4]	R/W		byte
313H-314H	默认网关[4] Default gateway [4]	R/W		byte
315H-31BH	仪表序列号[14] Instrument serial number [14]	R/W		byte
31CH-323H	端口号[8] Port number [8]	R/W		Word

注：[1] R—只读；R/W—可读，可写。

[2] $\times 10$, $\times 100$, $\times 1000$ —读取时实际值乘以相应的倍数上传，写入时应乘以相应的倍数写入。

Note: [1] R-Read only; R/W-Readable, writable.

[2] $\times 10$, $\times 100$, $\times 1000$ -When reading, upload with practical value multiply corresponding times; when writing, write in by multiplying corresponding times.

4 常见故障的诊断分析与排除方法

4 Diagnostic analysis and troubleshooting of common faults

4.1 辅助电源故障

4.1 Fault of auxiliary power supply

装置接通辅助电源后屏幕不亮？

The screen does not light after connecting the auxiliary power supply.

可能原因：外接端子线序错误。

Possible cause: the external terminal line sequence is wrong.

处理方法：拔出“温湿度 I”，“温湿度 II”，重新上电装置判断。

Handling method: pull out the external module at the joint of “temperature and humidity I”, “temperature and humidity II”, re-power on to judge.

4.2 环境温湿度显示故障

4.2 Fault of environment temperature and humidity display

温湿菜单下环境温湿度值无显示或显示“rupt”？

The environment and humidity value under temperature and humidity menu has no display or displays “rupt”?

可能原因：温湿度控制字未投入或温湿度模块未接好。

Possible cause: The temperature and humidity control word is not input or temperature and humidity module is not well connected.

处理方法：

Handling method:

1) 无显示时：“参数->定值”菜单将“温湿 1 投退”或“温湿 2 投退”或“温湿 3 投退”设置为投入。

1) When there is no display: “parameter -->definite value” menu will set the “temperature and humidity 1 out-of-service” or “temperature and humidity 2 out-of-service” or “temperature and humidity 3 out-of-service” as in-service.

2) 显示“rupt”时：检查“温湿度 I”，“温湿度 II”接口处的温湿度模块接入是否正确？

2) When displaying “rupt”: check whether the temperature and humidity module is correctly connected at the joint of “temperature and humidity I”, “temperature and humidity II”.

4.3 告警继电器动作故障

4.3 Fault of alarm relay operation

欠压，过压，过流，环境温度超温，无线节点温度高温定值越限而告警继电器不动作？

Undervoltage, overvoltage, environment temperature exceeds, wireless node high temperature definite value is out-of-limit and alarm relay does not work.

可能原因：相应的控制字未投入。

Possible cause: corresponding control word is not input.

处理方法：“参数->定值”菜单将相应的控制字设置为投入。

Handling method: “Parameter-->” menu should set corresponding control word as input.

4.4 一次模拟状态指示灯故障

4.4 Fault of primary simulated status indicator light

开关量输入与状态指示灯不对应或状态指示灯不亮？

Switch input and status indicator light is not corresponding or status indicator light is not on.

可能原因：状态指示灯设置错误。

Possible cause: status indicator light setting is wrong.

处理方法：“参数->状态指示”设置状态指示灯对应的开关量，如需常亮的设置为“ON”，未使用的设置为“OFF”。

Handling method: “Parameter-> status indicator” should set corresponding switch quantity of status indicator light. For example, if it needs normally on, set it as “ON”; if it is not used, set it as “OFF”.

4.5 通信故障

4.5 Communication fault

上位机或后台软件与装置通信错误？

There is something wrong with communication between upper computer or background software with device.

可能原因：装置地址或串口参数设置错误。

Possible cause: Device address or serial port parameter setting is wrong.

处理方法：“参数->通信”设置正确的装置地址或串口参数。

Handling method: “Parameter-> communication” should set correct device address or serial port parameters.

4.6 节点温度值显示故障

4.6 Fault of node temperature value display

ASD 主体“节温”菜单无温度值显示或无某一路温度值显示？

ASD main body “thermostat” menu has no temperature value display or no temperature value display of some path.

可能原因：电池开关未打开或传感器不配对。

Possible cause: battery switch is not opened or sensor is mismatched.

处理方法：

Handling method:

1) 查看无线温度传感器的电池开关是否拨到“ON”端？（电池开关从 OFF 端拨到 ON 端后，无线温度传感器上的绿灯亮灭闪烁 2 次表示开关接通正常，否则重复拨动）。

- 1) Check whether the battery switch of wireless temperature sensor is dialed to “ON” terminal (after battery switch is dialed to ON terminal from OFF terminal, the green light on wireless temperature sensor will flicker twice and it means that the switch is connected normally; otherwise, re-dial it).

2) 查看 ASD 主体上的条码与无线温度传感器上的条码是否一致，不一致时找到对应的无线温度传感器更换或重新配对无线温度传感器（详见本说明书 2.2.6 章节下的“ASD 主体与无线温度传感器的配对及校准”部分）。

- 2) Check whether the code on ASD main body and wireless temperature sensor is consistent. When it is inconsistent, find out corresponding wireless temperature sensor to replace or rematch wireless temperature sensor (See “Matching and calibration of ASD main body and wireless temperature sensor” part under Section 2.2.6 of the specification).

总部：安科瑞电气股份有限公司

地址：上海市嘉定区育绿路 253 号

电话：0086-021-69158161

网址：www.acrel.cn

邮箱：acrelsh@email.acrel.cn

邮编：201801

生产基地：江苏安科瑞电器制造有限公司

地址：江苏省江阴市南闸街道东盟工业园区东盟路 5 号

电话：0086-510-86179966

网址：www.jsacrel.cn

邮箱：jyacrel001@email.acrel.cn

邮编：214405

Headquarters: Acrel Co., Ltd.

Trade Company: Acrel E-Business(Shanghai)Co., Ltd.

Address: No.253 Yulv Road, Jiading District, Shanghai, China

TEL.: 0086-21-69156352

Web-site: www.acrel-electric.com

E-mail: sales@acrel-electric.com

Postcode: 201801

Manufacturer: Jiangsu Acrel Electrical Manufacturing Co., Ltd.

Address: No.5 Dongmeng Road, Dongmeng industrial Park, Nanzha Street, Jiangyin City, Jiangsu Province, China

TEL./Fax: 0086-510-86179970

Web-site: www.jsacrel.com

E-mail: sales@email.acrel.cn

Postcode: 214405