

AM4 微机保护装置

AM4 Microcomputer Protection Device

操作说明书 V2.4
Operational Manual V2.4

申 明

DECLARATION

版权所有，未经本公司之书面许可，此手册中任何段落，章节内容均不得被摘抄、拷贝或以任何形式复制、传播，否则一切后果由违者自负。

本公司保留一切法律权利。

All rights reserved. No part of this publication may be reproduced, stored in a retrieval system, or transmitted in any form by any means, electronic, mechanical photocopying, recording, or otherwise without prior permission of our company. The violator will bear the dependent legal responsibility.

We reserve all the rights.

本公司保留对本手册所描述之产品规格进行修改的权利，恕不另行通知。

订货前，请垂询当地代理商以获悉本产品的最新规格。

We reserve all the rights to revise product specification without notice.
Please consult local agent to get the latest information of our products specification.

目 录

CONTENTS

第一章 装置介绍.....	1
Chapter 1 Device Introduction.....	1
1 概述.....	1
1 Information.....	1
2 装置功能对照表.....	1
2 Device Function.....	1
第二章 技术参数.....	3
Chapter 2 Technical Parameters.....	3
1 额定参数.....	3
1 Rated parameters.....	3
1.1 工作电源.....	3
1.1 Power supply.....	3
1.2 输入激励电压.....	3
1.2 Rated voltage.....	3
1.3 输入激励电流（保护电流）.....	3
1.3 Rated current (Protection current).....	3
1.4 频率.....	4
1.4 Frequency.....	4
1.5 开关量输入.....	4
1.5 Digital Input.....	4
1.6 开关量输出.....	4
1.6 Digital Output.....	4
2 正常工作环境条件.....	4
2 Normal working conditions.....	4
第三章 装置操作说明.....	5
Chapter 3 Operational Manual.....	5
1 前面板说明.....	5
1 Surface instructions.....	5
2 按键说明.....	5
2 Key instructions.....	5
3 菜单说明.....	6
3 Menu instructions.....	6
3.1 快速导航.....	7
3.1 Fast navigation.....	7
3.2 配置.....	8
3.2 Configuration.....	8
3.3 定值.....	9
3.3 Parameter.....	9
3.4 调试.....	11
3.4 Debug.....	11

3.5 记录	12
3.5 SOE	12
3.6 通讯	13
3.6 Communication	13
3.7 控制	14
3.7 Control	14
3.8 时间	14
3.8 Time	14
3.9 信息	14
3.9 Information	14
第四章 装置外形尺寸及安装方法	16
Chapter 4 Device dimension and installation method	16
1 外形及开孔尺寸	16
1 Shape and hole dimension	16
2 安装方法	16
2 Installation method	16
第五章 装置背部端子图及接线方法	18
Chapter 5 Device back terminal diagram and wiring method	18
1 电气接线图	18
1 Electrical wiring diagram	18
2 接线方法	19
2 Wiring method	19
第六章 维护及其他问题处理	22
Chapter 6 Maintenance and other issues	22
附录 A 装置出厂默认定值表	23
Accessories A Setting value	23
附录 B 装置事件记录清单	32
Accessories B SOE List	32

第一章 装置介绍

Chapter 1 Device Introduction

1 概述

1 Information

AM4 系列微机保护装置集保护、控制于一体，适用于 35kV 及以下电压等级的用户终端变电站（所），可实现用户变电站的全面保护和控制。应用领域覆盖电力、水利、交通、石油、化工、煤炭、冶金等行业。

AM4 series microcomputer protection device are applicable to the user substation which the input voltage is 35kv or above. AM4 can be used to protect and control the user substation, and is be widely used to Power Industry, Water conservancy industry, Traffic Industry, Oil industry, Chemical industry, Coal Industry, Metallurgical Industry and so on.

保护装置采用先进成熟可靠的保护原理和算法，抗干扰性能强，可靠性高，保护实现方式灵活，通讯采用冗余设计。装置具备 12 路开关量采集和 5 路继电器输出，能与 Acrel-2000 电力监控软件配合，可以实现无人值班的终端用户变电站配电自动化系统。

The advanced and reliable protection principles and algorithms are used in AM4, and AM4 series protection devices have so many advantages such as anti-jamming performance, high reliability, flexible way to achieve protection, communication uses redundancy design.

The device has ample hardware interfaces, such as 12 DI、5 DO、8AI and so on. The AM4 can be used to communicate with The Acrel-2000 power monitoring system to support Unattended substation system.

2 装置功能对照表

2 Device Function

功能 Function	用途 Application	电流型 Current type	电压型 Voltage type
	型号 Type	AM4-I	AM4-U1
电流采集 Input Current		4	0
电压采集 Input Current		4	4
开关量采集 DI		12	12
继电器输出 DO		5	5
保护功能 Protective Function			
过流（三段、反时限） over current protection (three stage, inverse time)		√	
零序过流（两段、反时限） Over zero-current protection (two stage, inverse time)		√	
负序过流（两段、反时限） Negative sequence over-current (two stage, inverse time)		√	

重合闸 Reclose	√	
过负荷跳闸/告警 Overload trip/alarm	√	
低频减载 Low-frequency load shedding	√	
后加速过流 After accelerating over-current	√	
过电压跳闸 Over voltage trip	√	
低电压跳闸 Under voltage trip	√	
FC 闭锁 FC Block	√	
控故障告警 Control circuit fault alarm	√	
非电量跳闸/告警 Non electric trip/alarm	√	
低电压告警 Under voltage alarm	√	√
过电压告警 Over voltage alarm	√	√
零序过压告警 Over zero-voltage alarm	√	√
PT 断线告警 PT disconnection alarm	√	√
自产零序过压告警 Self-produced over zero-voltage alarm		√
通讯规约 Communication protocol		
ModBus-RTU	√	√
IEC60870-5-103	√	√
辅助功能 Accessibility		
故障录波 Fault recording	√	

注：√表示具备此功能，■表示可选功能，空白表示无此功能。

Note: √ represent with this feature, ■ represents optional feature, blank represents no function.

第二章 技术参数

Chapter 2 Technical Parameters

1 额定参数

1 Rated parameters

1.1 工作电源

1.1 Power supply

工作电源: AC/DC220V 或 AC/DC110V 或 DC48V (见装置接线图)

Power supply: AC/DC220V, or AC/DC110V, or DC48V (Reference the wiring diagram)

范 围: 工作电源 $\times (1 \pm 20\%)$

Range: Power supply $\times (1 \pm 20\%)$

最大功耗: $\leq 10\text{W}$ (直流)

Maximum power consumption: $\leq 10\text{W}$ (DC)

1.2 输入激励电压

1.2 Rated voltage

额 定 值: AC 100V 或 $100/\sqrt{3}\text{V}$

Rated voltage: AC 100V or $100/\sqrt{3}\text{V}$

测量范围: 1~120V

Range: 1~120V

准 确 度: $\pm 0.5\%$

Accuracy: $\pm 0.5\%$

功率损耗: 每相功率损耗不大于 0.5VA

Power consumption: $\leq 0.5\text{VA}$ (single phase)

过载能力: 1.2 倍额定电压, 连续工作;
2 倍热过载, 允许 10s。

Overload capacity: 1.2 times rated voltage for continuous work;
2 times for 10 seconds.

1.3 输入激励电流 (保护电流)

1.3 Rated current (Protection current)

额 定 值: AC 5A 或 1A (见装置接线图)

Rated current: AC 5A/1A (See the device wiring diagram)

测量范围: $0.04I_n \sim 15I_n$

Range: $0.04I_n \sim 15I_n$

功率损耗: 每相功率损耗不大于 0.5VA

Power consumption: $\leq 0.5\text{VA}$ (single phase)

过载能力: 2 倍额定电流, 连续工作;
40 倍额定电流, 允许 1s。

Overload capacity: 2 times rated current for continuous work;
40 times for 1 second.

1.4 频率

1.4 Frequency

额定频率: 50Hz 或 60Hz

Rated frequency: 50Hz or 60Hz

频率范围: 45~55Hz 或 60Hz

Range: 45~55Hz or 60Hz

准确度: $\pm 0.1\text{Hz}$

Accuracy: $\pm 0.1\text{Hz}$

1.5 开关量输入

1.5 Digital Input

额定电压: AC/DC220V, AC/DC110V, DC48V (同工作电源)

Rated Voltage: AC/DC220V, AC/DC110V, DC48V (similar to power supply)

电压范围: 额定电压 $\times (1 \pm 20\%)$

Voltage range: Rated Voltage $\times (1 \pm 20\%)$

功率消耗: 每通道功率消耗 $\leq 1\text{W}$ (DC220V)

Power consumption: $\leq 1\text{W}$ (DC220V) (single channel)

1.6 开关量输出

1.6 Digital Output

机械寿命: ≥ 10000 次

Mechanical life: ≥ 10000

接通容量: $\geq 1000\text{W}$, L/R = 40ms

Switching capacity: $\geq 1000\text{W}$, L/R = 40ms

导通电流: 连续 $\geq 5\text{A}$, 短时 (200ms) $\geq 30\text{A}$

On current: continuous $\geq 5\text{A}$, short time (200ms) $\geq 30\text{A}$

断开容量: $\geq 30\text{W}$, L/R = 40ms

Interrupting capacity: $\geq 30\text{W}$, L/R = 40ms

2 正常工作环境条件

2 Normal working conditions

环境温度: $-10^{\circ}\text{C} \sim +55^{\circ}\text{C}$;

Ambient temperature: $-10^{\circ}\text{C} \sim +55^{\circ}\text{C}$;

装置的贮存、运输允许的环境温度为 $-25^{\circ}\text{C} \sim +70^{\circ}\text{C}$;

Device storage, transport allows the ambient temperature is $-25^{\circ}\text{C} \sim +70^{\circ}\text{C}$;

相对湿度: 5%~95% (产品内部不凝露, 不结冰);

Relative humidity: 5%~95% (The product does not condensation and freeze inside);

海拔高度: $\leq 2500\text{m}$ 。

Altitude: $\leq 2500\text{m}$ 。

第二章 装置操作说明

Chapter 3 Operational Manual

1 前面板说明

1 Surface instructions

装置的人机交互主要在面板上进行，包括三个部分：液晶显示、LED 指示灯、按键。

The man-machine interaction of the device is mainly carried out on the surface, including three parts: liquid crystal display, LED lights, keys.

液晶可以显示电流、电压、功率等电参量实时值，遥信量，事件记录，装置参数，定值参数，时间，装置版本号信息等。

Liquid crystal can display current, voltage, power and other electrical parameters of real-time value, remote signals, event records, device parameters, setting parameters, time, device version information and so on.

LED 灯用来指示装置的运行状态、保护动作等信息。

LED lights are used to indicate the device's operating status, protection and other information.

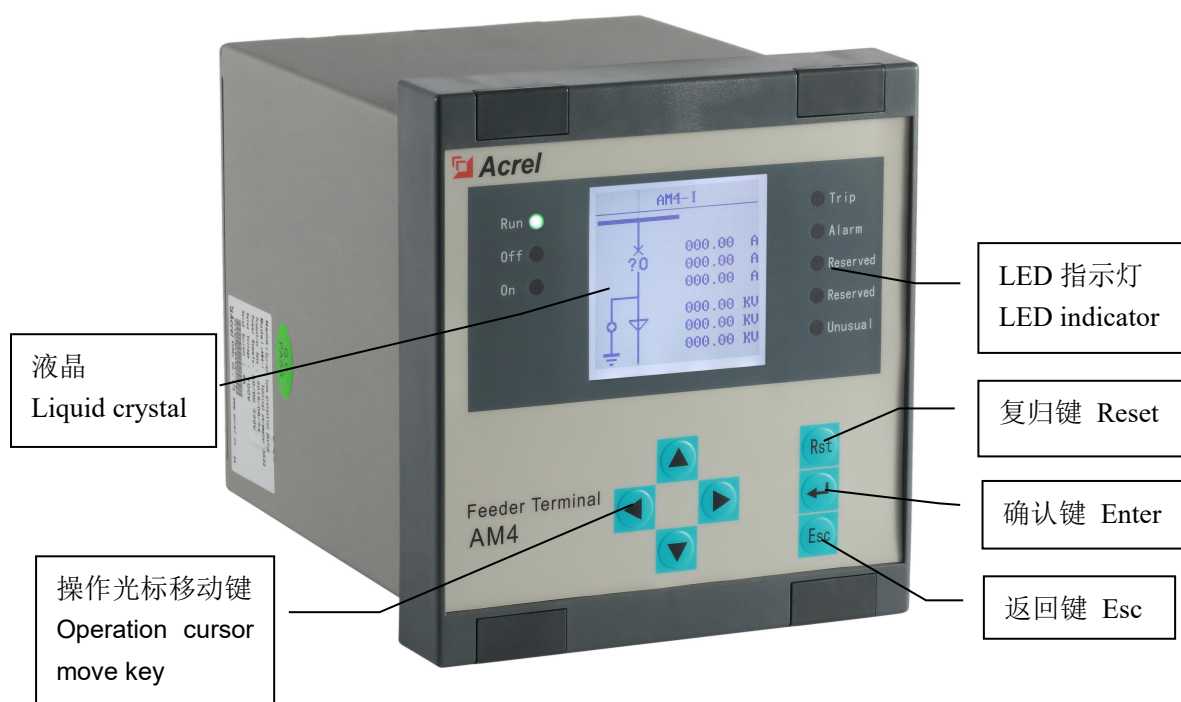


图 3.1 AM4 前面板

Figure 3.1 AM4 Surface

2 按键说明

2 Key instructions

按键包括上、下、左、右、确认键、返回键及复归键，实现人机交互功能。

Keys include Up, Down, Left, Right, Enter, Esc and Reset, to achieve man-machine interaction.

表 3.1 AM4 按键功能说明

Table 3.1 AM4 Key function instructions

按键 Key	主要功能 Function	按键 Key	主要功能 Function
Rst	复归 Reset	▲	向上移动选项或数字增大 Up/Increase
←	确认 Enter	▼	向下移动选项或数字减小 Down/Decrease
Esc	返回 Esc	◀	向左移动选项或页面前翻 Left
		▶	向右移动选项或页面后翻 Right

3 菜单说明

3 Menu instructions

装置上电即进入主界面，主界面分三个界面显示：运行界面、遥测量界面、遥信量界面。各个界面内通过上下键显示更多内容，各个界面之间可以通过左右键来切换显示。

The device is powered on to enter the main interface, the main interface is divided into three interfaces: running interface, telemetry interface, remote interface. Each interface can display more content through the up and down keys, and each interface can switch between the display through the left and right keys.

AM4		
	000.00	A
	000.00	A
	000.00	A
	000.00	KV
	000.00	KV
	000.00	KV

图 3.2 运行界面

遥测	当前值	单位
Ia	0000.00	A
Ib	0000.00	A
Ic	0000.00	A
IO	0000.00	A
UAB	0000.00	V
UBC	0000.00	V
UCA	0000.00	V
U4	0000.00	V

图 3.3 遥测量界面

遥信	状态
断路器合位	分
断路器分位	分
手车运行位置	分
手车试验位置	分
接地刀闸	分
远方状态	分
弹簧未储能	分

图 3.4 遥信量界面

AM4		
	000.00	A
	000.00	A
	000.00	A
	000.00	KV
	000.00	KV
	000.00	KV

Figure3. 2 Run interface

Name	Value	Unit
Ia	0000.00	A
Ib	0000.00	A
Ic	0000.00	A
IO	0000.00	A
UAB	0000.00	V
UBC	0000.00	V
UCA	0000.00	V
U4	0000.00	V

Figure3. 3 Telemetry interface

Name	Stat
CCB On	Of
CCB Off	Of
Working Position	Of
Testing Position	Of
Grouding Switch	Of
Remote	Of
Discharge	Of

Figure3. 4 Remote interface

3.1 快速导航

3.1 Fast navigation

装置菜单为多级菜单，在任一幅主界面里按“确认”键即进入主菜单，主菜单分为8个子菜单，如图3.5，由子菜单名称、图标构成。选定任一子菜单后按“确认”键进入菜单，按“返回”键返回上级菜单。图3.6为快速导航示意图，可以依据该图迅速查找相关参数。

The device menu is multi-level menu, users can press the "Enter" key to enter the main menu. The main menu is divided into 8 sub-menus, as shown in figure 3.5, which is composed of submenu name and icon. After selecting a submenu, press "Enter" key to enter the menu and press "Esc" key to return to the superior menu. Figure 3.6 is a quick navigation map, which can be used to quickly find relevant parameters.

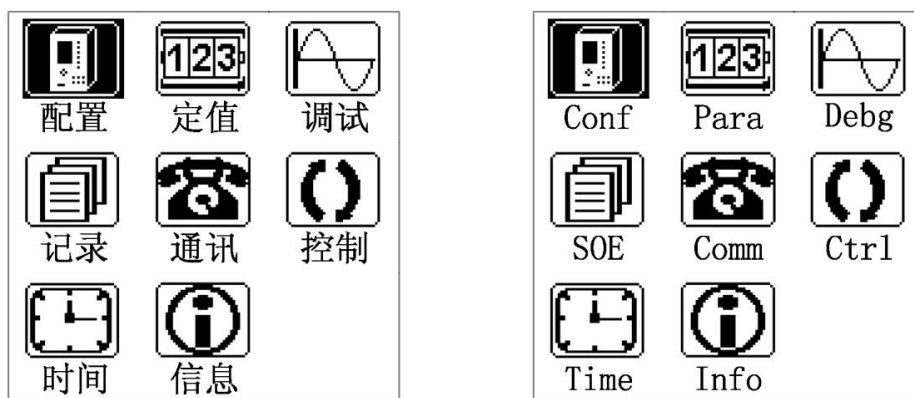


图 3.5 主菜单
Figure 3.5 Main menu

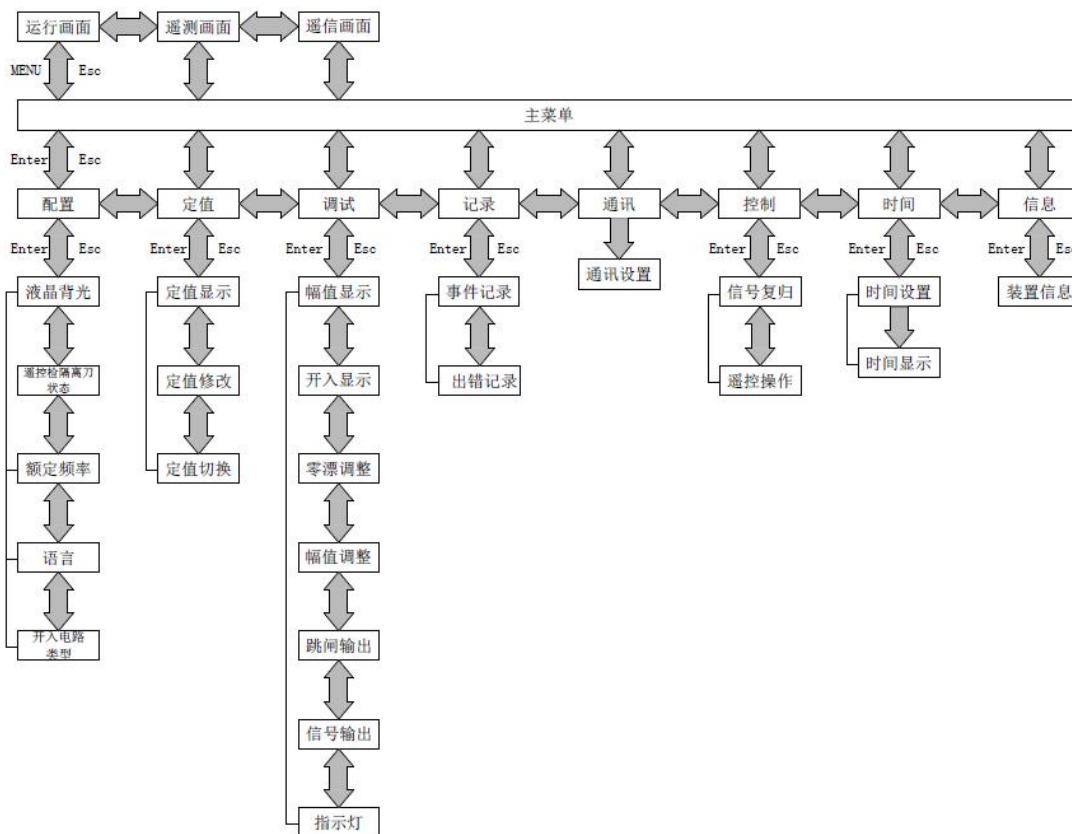


图 3.6 快速导航示意图

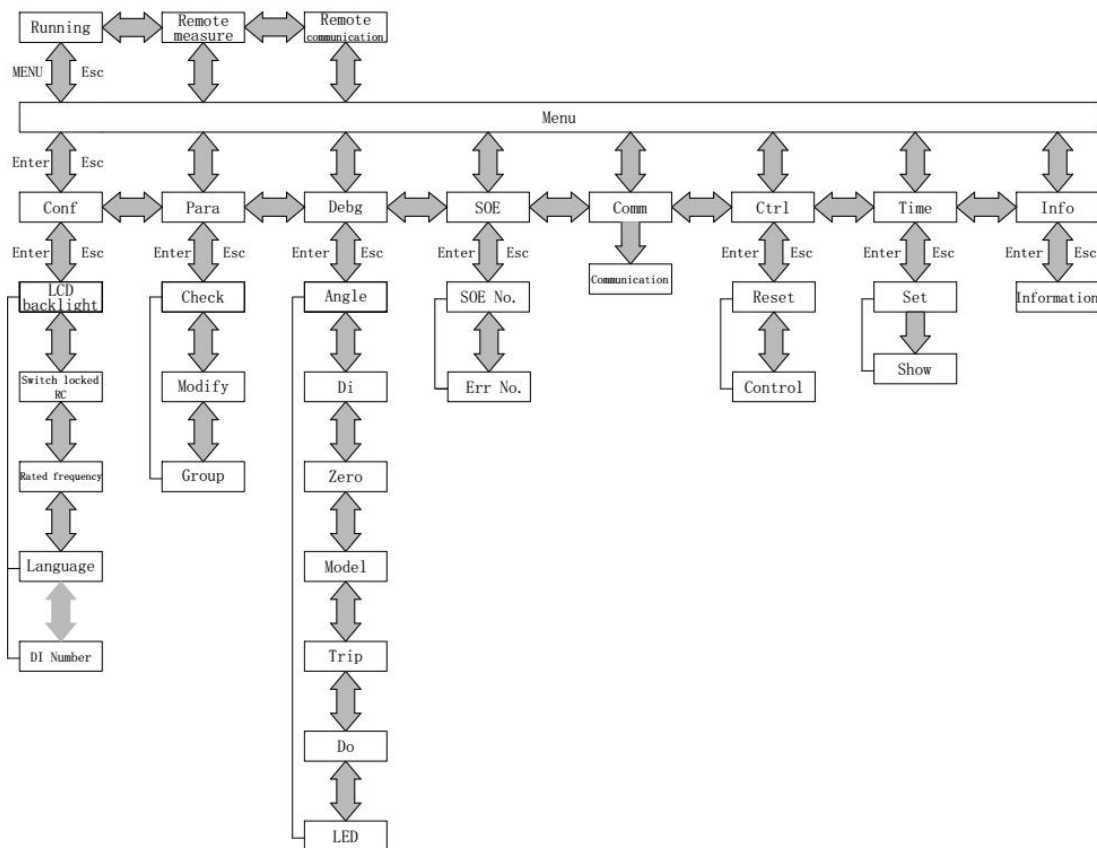


Figure 3.6 Main navigation

3.2 配置

3.2 Configuration

“配置”菜单可以设置液晶背光时间，如图 3.7，修改完成后，按“确认”键退出修改，再按“返回”键返回，装置会跳出数据保存界面，如图 3.8，按“确认”键保存修改并返回主菜单，按“返回”键不保存修改且返回主菜单。

“Conf” menu can set the LCD backlight time, as shown in figure 3.7, after the change is completed, press the “Enter” key to exit the changes, and then click “Esc” button to return to, the device will jump out of the data interface, as shown in figure 3.8, press “Enter” button to save the changes and return to the main menu, press the “Esc” key does not save the changes and return to the main menu.

Used can use the “Enter” key and “Esc” key to set the parameters such as LCD backlight、Switch locked RC、Rated frequency、language and so on in AM4.

参数配置	
液晶背光时间	999秒
遥控检隔离刀状态	否
额定频率	50Hz
语言	中文
开入电路类型	8DI+4DI

图 3.7 液晶背光时间设置

参数配置	
液晶背光时间	999秒
遥控检隔离刀状态	否
额定频率	50Hz
语言	中文
开入电路类型	8DI+4DI
数据保存?	
Enter:保存 Esc:退出	

图 3.8 数据保存提示

setting	
LCD backlight	999s
Switch locked RC	no
Rated frequency	50Hz
Language	English
DI Number	8DI+4DI

setting	
LCD backlight	999s
Switch locked RC	no
Rated frequency	50Hz
Language	English
DI Number	8DI+4DI
Save?	
Enter:Save Esc:Exit	

Figure 3.7 LCD backlight time settings Figure 3.8 Data saving

3.3 定值

3.3 Parameter

“定值”菜单里有定值显示、定值修改、定值切换三个子菜单，如图 3.9。

The menu “Para.” has 3 submenus: Check、Modify、Group, as shown in Figure 3.9.

3.3.1 定值显示

3.3.1 Check

“定值显示”菜单中有选择定值区、运行定值区两个子菜单。选择定值区里有四组有效定值，分别为 00、01、02、03 四个区号，选择相应区号，如图 3.10，按“确认”键进入定值显示。所有定值分页显示，按左右键可分页查看，如图 3.11。运行定值区里显示装置当前运行的定值区。

The “Check” menu has two submenus, which are selected value section and running value section. The selected value section has 4 section:00、01、02 and 03, as shown in figure3.10. Each section can be set different values. The running value section is shown the nowadays value of AM4, all value pagination displays, press left and right key to view, as shown in figure 3.11.

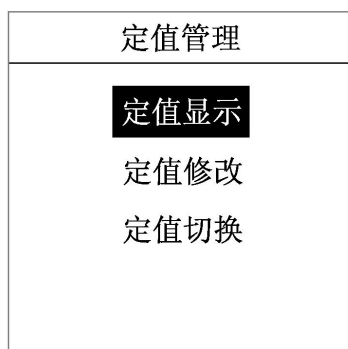


图 3.9 定值菜单

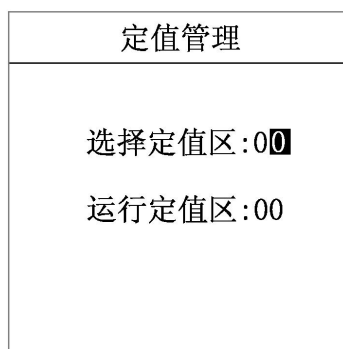


图 3.10 设置选择定值区

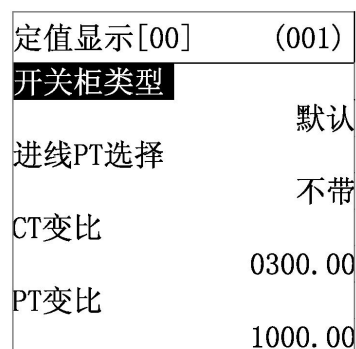


图 3.11 定值显示

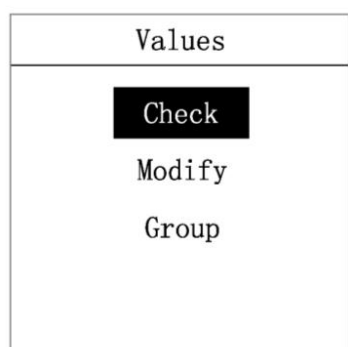


Figure 3.9 Parameter

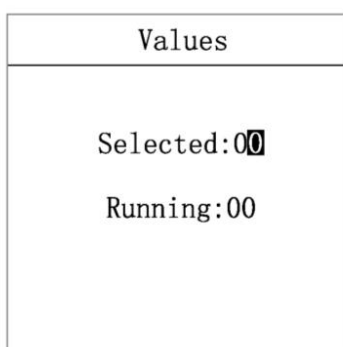


Figure 3.10 Selection area

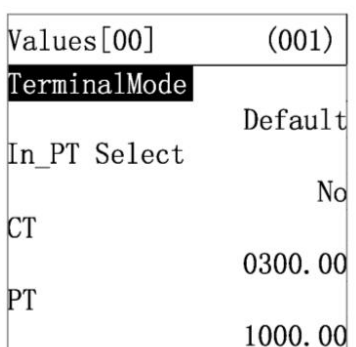


Figure 3.11 Check

3.3.2 定值修改

3.3.2 Modify

“定值修改”菜单有选择定值区、运行定值区两个子菜单，该菜单初始密码为“0008”。

The “Modify” menu has two submenus in the selected value area and the running value area. The initial password of this menu is “0008”.

在选择定值区内设置需修改的定值区号，按“确认”键进入定值修改界面。这里分页显示所有定值信息，可通过上下左右键选择需修改的定值，先按“确认”键，再按上下键设置修改内容，如图 3.13。修改完成后，按“确认”键确定，再对下一个需要修改的定值进行修改，待全部定值修改完成后，再按“返回”键退出，这时若数据有改动，则装置会弹出同图 3.8 所示的数据保存对话框，按“确认”键保存修改并返回定值管理菜单，按“返回”键不保存且返回定值管理菜单。

Set the value area code to be modified in the fixed value area, and press “Enter” to enter the value modification interface. Here pagination displays all the value information, and use can select the value that needs to be modified by selecting the left and right keys, press the “Enter” button first, and then press the up and down key to set the modified content, as shown in figure 3.13. After the set is completed, press the “Enter” button, then set the next one as the same way.

When the all setting is completed, press “Esc” button to exit, at this time if the data changes, the device will pop up with the data dialog box shown in figure 3.8, press “enter” button to save the changes and return to value management menu, click “Esc” button is not saved and to return to value management menu.

运行定值区只显示装置当前运行的定值区号，这里不做修改。

The running value area only displays the current running value area of the device. and no modification is made here.

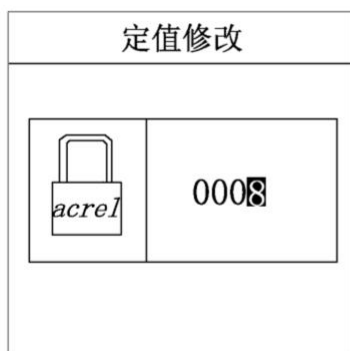


图 3.12 输入密码对话框

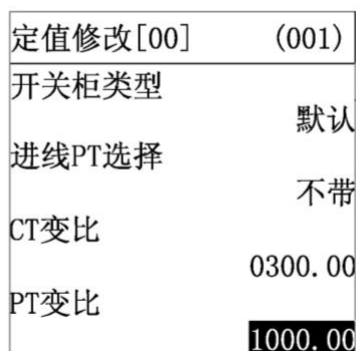


图 3.13 定值修改

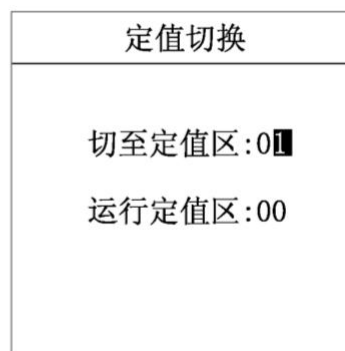


图 3.14 定值切换

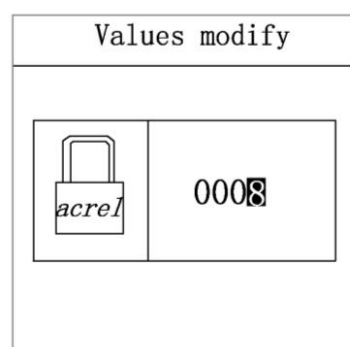


Figure 3.12 Enter password

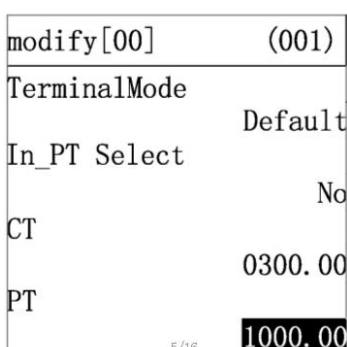


Figure 3.13 Modify

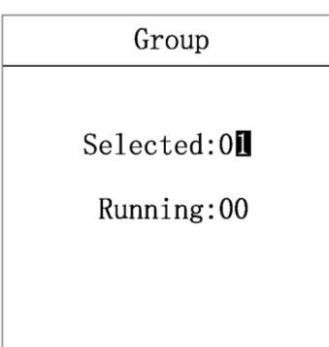


Figure 3.14 Group

3.3.3 定值切换

3.3.3 Group

“定值切换”菜单有切至定值区、运行定值区两个子菜单，该菜单密码为“0008”。切至定值区内有00-03四个有效定值区可供切换，设置好后，按“确认”键确定，再按“返回”键返回主菜单。运行定值区将显示当前运行的定值区号，如图3.14。

The “Group” menu has two submenus, which are cut to the value area and run the value area. The password of this menu is “0008”. The selected section shows the expected section which uses want to set, which can be set as 00-03. The running section shows the nowadays value of the device AM4. The details are shown in figure 3.14.

After setting, press the “Enter” button to determine, and then press the “esc” key to return to the main menu. The running value area will display the current running value area of the device, as shown in figure 3.14.

3.4 调试

3.4 Debug

“调试”菜单为出厂前测试装置使用，可对装置进行零漂调整、幅值调整、继电器输出、指示灯输出测试。

The “Debug” menu is used to manufacturer to test the device before it leaves the factory. The function includes zero adjustment、 amplitude adjustment、 digital output、 lamp output and so on.

该菜单功能使用时请与制造商联系。

When use the “Debug.” function, please contact the manufacturer first!

3.5 记录

3.5 SOE

“记录”菜单中可以查看事件记录、出错记录两类信息。

By “SOE” menu, users can view two types of event record, error record and event record.

3.5.1 事件记录

3.5.1 Event record

“事件记录”菜单可显示事件序号、事件总数、事件代码、事件发生时间、事件名称、动作类型（动作或告警）等信息。如果是保护动作引起事件记录，还会记录事件发生时刻动作元件动作值和时间，如图 3.15 所示。装置可保存大于 200 条事件记录。

“SOE” menu shows the event sequence, event number, event code, event time, event action type (action or alarm), and so on. It can also record the action values and time of the protection event, as shown in figure 3.15. The device can save more than 200 event record.

3.5.2 出错记录

3.5.2 Error record

“出错记录”菜单可显示出错序号、出错总数、出错时间、出错名称、出错码等信息，如图 3.16 所示。装置可保存大于 200 条记录。

“Error” menu shows the error sequence, event number, error time, error name, error code and so on, as shown in figure 3.16. The device can save more than 200 event record.

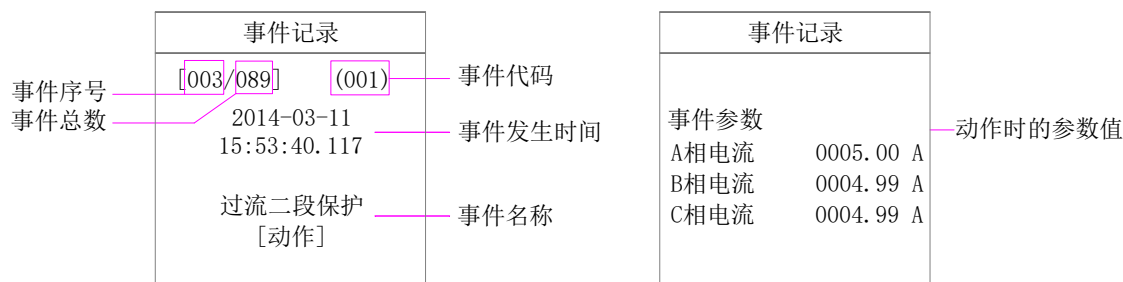


图 3.15 事件记录画面

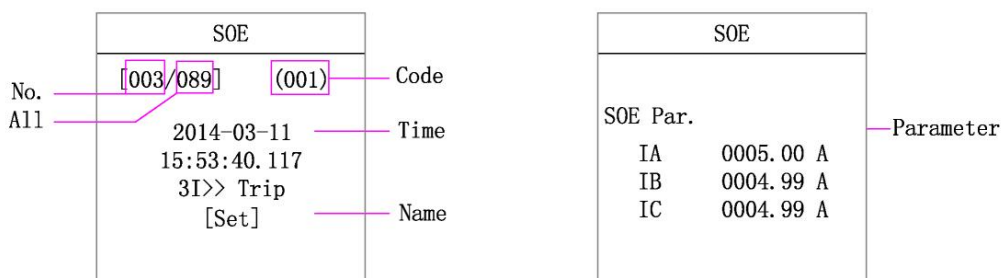


Figure 3.15 Event record screen

出错记录	Error
[003/099]	[003/099]
2014-03-11 14:34:38	2014-03-11 14:34:38
软件属性初始化	Software Init
出错码: 0x00000003	Error No.: 0x00000003

图 3.16 出错记录画面 Figure 3.16 Error event screen

3.6 通讯

3.6 Communication

“通讯”菜单可设置通讯地址及波特率，如图 3.17。通讯参数可从表 3.2 选择参数进行设置。设置完成后先按“返回”键退出，然后按“确认”键保存，再按“返回”键返回主菜单。

The “Comm” menu can set the communication address and baud rate, as shown in figure 3.17. Communication parameters can be set from table 3.2 selection parameters. After setting, press “Esc” key to exit, then press “Enter” to save, then press “Esc” key to return to the main menu.

表 3.2 通讯参数设置

Table 3.2 Communication setting parameter

设置量 Setting parameter	参数 Parameter
装置地址 Device address	0~255
比特率 Baud rate	4800、9600、19200、57600、115200
数据位 Data bits	8、9
停止位 Stop bit	1、1.5、2
校验方式 Calibration method	无校验、偶校验、奇校验 No calibration、Even calibration、Odd calibration
规约选择 Statutory choice	MODBUS、IEC103

通讯设置		Communication	
装置地址	000	Addr	000
COM1规约	Modbus	COM1protocol	Modbus
COM1波特率	9600	COM1baudrate	9600
COM1数据位	8	COM1dateBit	8
COM1停止位	1	COM1stopBit	1
COM1校验方式	无校验	COM1parity	none

图 3.17 通讯设置界面 Figure 3.17 Communication setting screen

3.7 控制

3.7 Control

“控制”菜单为出厂前测试装置使用，可对装置进行遥控分闸、遥控合闸及信号复归操作。

The “Ctrl” menu is used to manufacturer to test the device before it leaves the factory. The function includes remote control switch、remote control close、signal revert.

该菜单功能使用时请与制造商联系。

When use the “Ctrl” function, please contact the manufacturer first!

3.8 时间

3.8 Time

“时间”菜单用于修改时钟。如图 3.18，时间设置完成后按“确认”键即修改成功，再按“返回”键返回主菜单。

The menu “Time” is used to set the device clock. The setting method as shown in Figure 2.15，when the clock is set，press the “enter” key and then press the “Esc” key，the set is successful.

3.9 信息

3.9 Information

“信息”菜单可显示本装置基本信息包括装置名称、版本号、校验码、硬件配置生成时间、软件配置生成时间、保护逻辑图生成时间及逻辑图版本号等，如图 3.19 所示。

“Info” menu can display the basic information include Name、Version、Check code、Hardware、software、logic、logic version and so on，as shown in figure 3.19.

装置时间
2014-03-10 15:45:30
2000-01-01 03:10:52

图 3.18 时间设置

装置信息
AM4
版本号: 1.0
校验码: 0x0500
硬件配置: 2014-03-10_12:34:34
软件配置: 2014-03-10_12:34:38

图 3.19 装置信息

Time
2014-03-10 15:45:30
2000-01-01 03:10:52

Figure 3.18 Time setting

Information
AM4
Version: 1.0
CRC: 0x0500
Hardware:
2014-03-10_12:34:34
Software:
2014-03-10_12:34:38

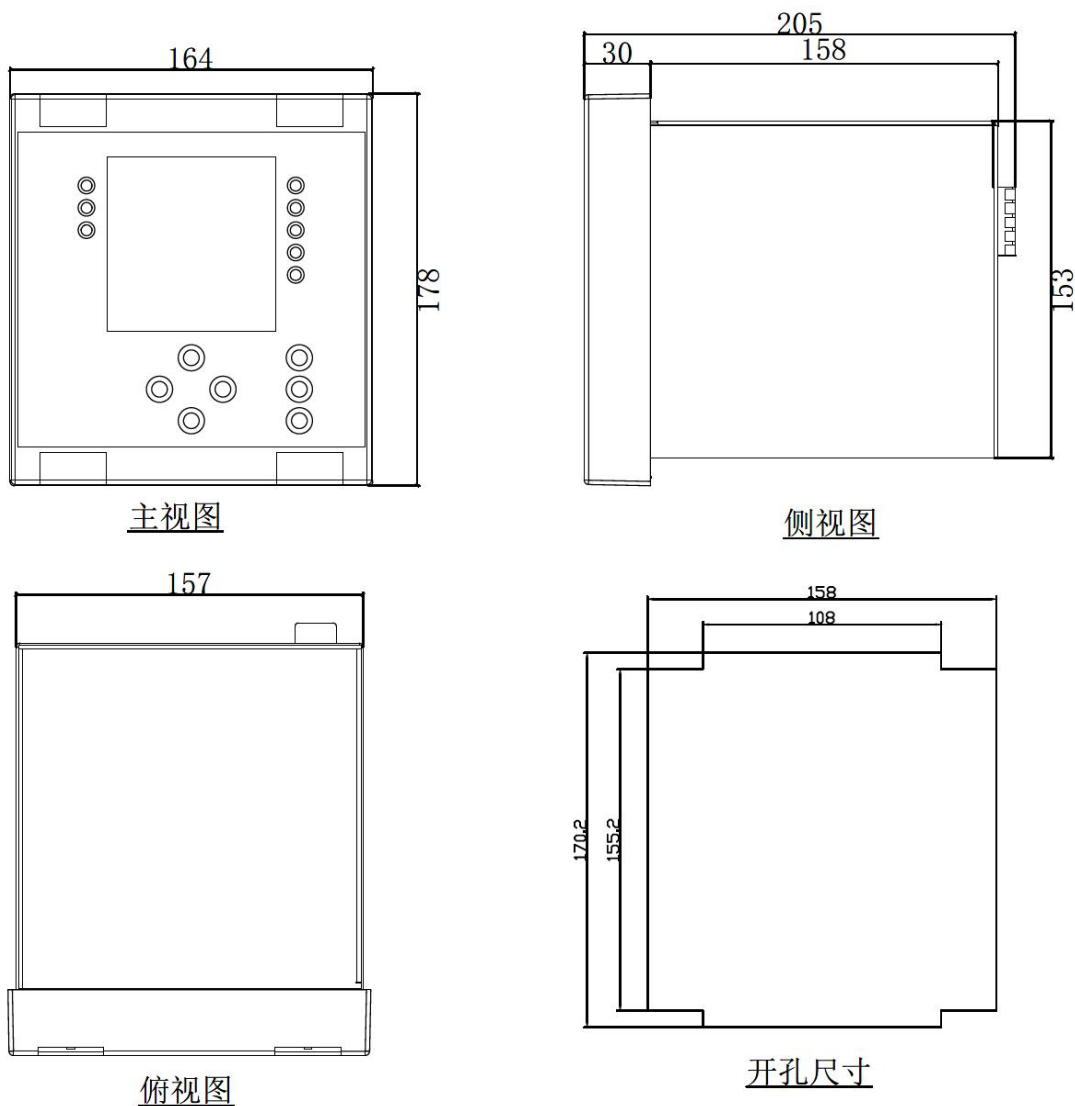
Figure 3.19 Device information

第四章 装置外形尺寸及安装方法

Chapter 4 Device dimension and installation method

1 外形及开孔尺寸

1 Shape and hole dimension



2 安装方法

2 Installation method

AM4 系列微机保护装置采用面板嵌入式安装，首先在屏体面上按开孔尺寸开孔，如图 4.1。再将装置按图 4.2 所示放入开孔中，直到装置面板靠住机柜的面板。将支架放置于机柜面板的内部（上下各有一个支架），如图 4.3，并用 4 个螺丝固定，使装置牢固固定在机柜面板上，最后盖上 4 个翻盖即可。（翻盖上方有小缺口，拆卸时需用一字螺丝刀插入小缺口将翻盖取下。）

The AM4 series microcomputer protection device adopts the panel embedded installation.

First, the hole size is opened on the screen, as shown in figure 4.1. Put the device in the open hole as shown in FIG. 4.2 until the panel of the device is on the cabinet. Placed stents in the interior of the cabinet panel (up and down each have a stent), as shown in figure 4.3, and four screws, make the device firmly fixed

on the cabinet panels, the last four flip cover.(there is a small gap in the top of the cover, and a screwdriver will be needed to remove the cover.)

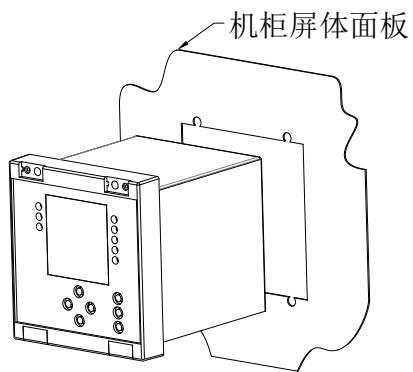


图 4.1
Figure 4.1

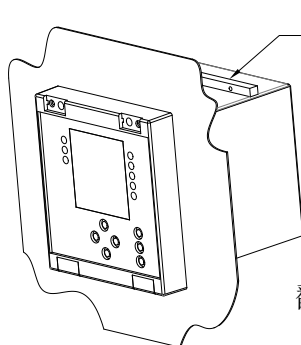


图 4.2
Figure 4.2

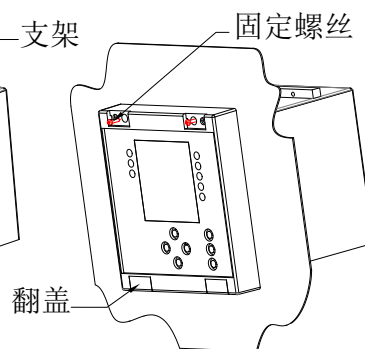


图 4.3
Figure 4.3

第五章 装置背部端子图及接线方法

Chapter 5 Device back terminal diagram and wiring method

1 电气接线图

1 Electrical wiring diagram

AM4 电气接线图如图 5.1(a)、5.1(b)、5.1(c)所示，包括交流量接线、开入开出接线、通讯接线和辅助电源接线。

The electrical wiring diagram of AM4 is shown in figure 5.1 (a), 5.1 (b) and 5.1 (c), including AI(analogue input),DI(digital input),DO(digital output), communication connection and auxiliary power connection.

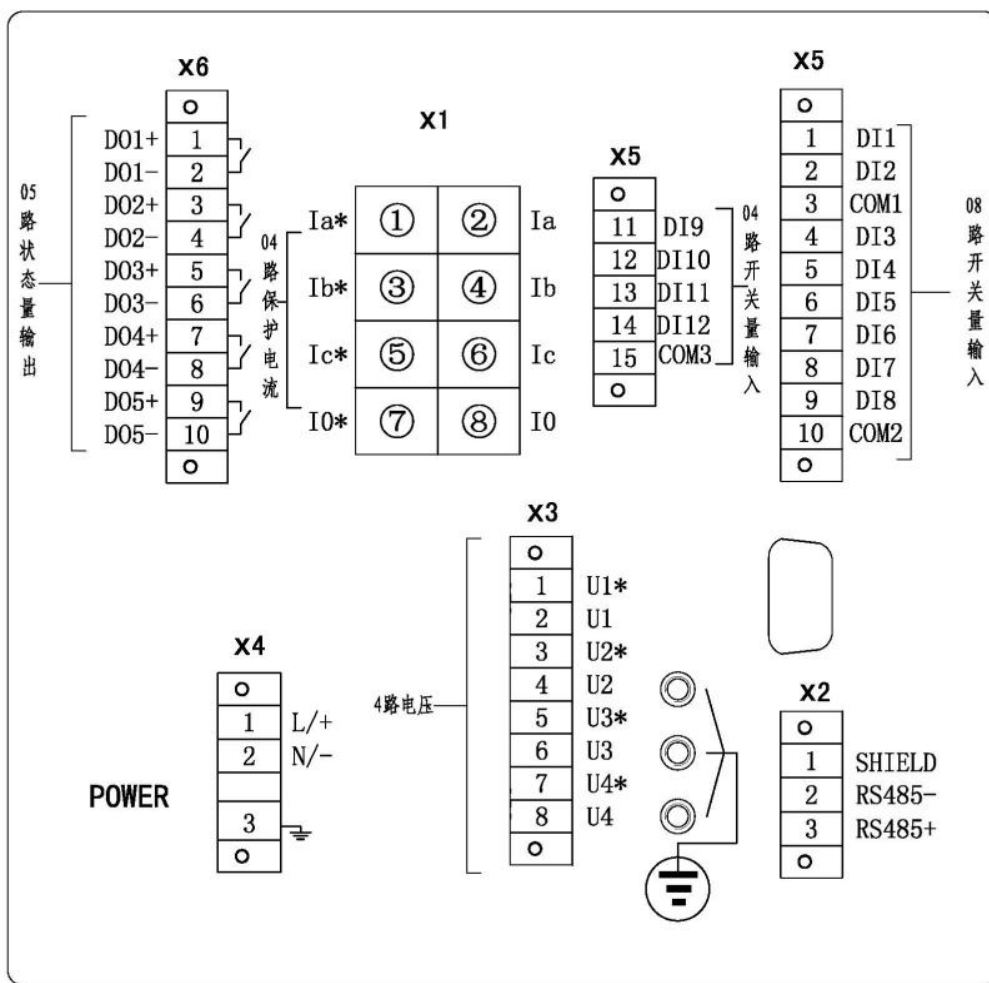


图 5.1 (a) AM4-I 电气接线图

Figure 5.1(a) AM4-I Electrical wiring diagram

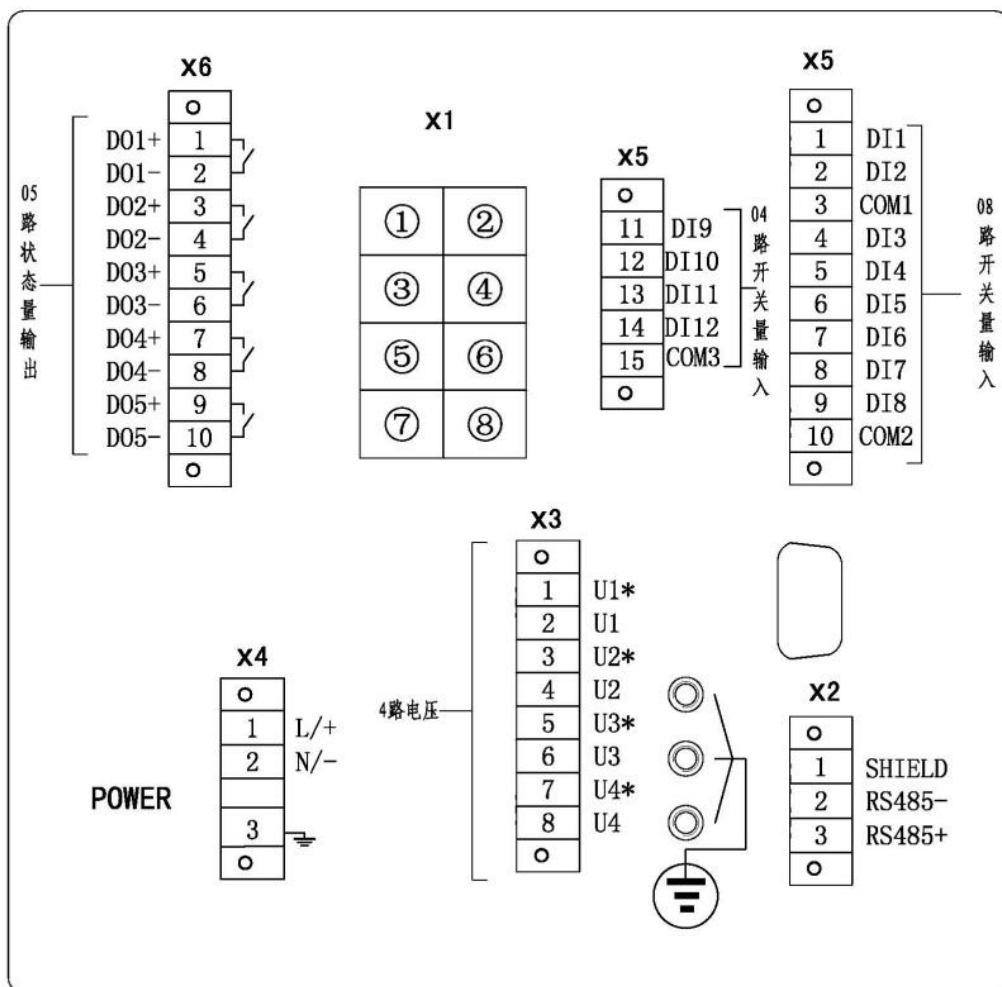


图 5.1 (b) AM4-U1 电气接线图

Figure 5.1 (b) AM4-U1 Electrical wiring diagram

2 接线方法

2 Wiring method

端子 X1 为交流电流接线，Ia、Ib、Ic 为保护相电流接入，I0 为零序电流接入。端子 X3 为交流电压量接线，U1、U2、U3 为三相电压接入，U4 为外接零序电压接入。交流回路一般都采用三相四线制接线，若采用三相三线制可按图 5.2 接线。

Terminal X1 is ac current input connection, Ia, Ib and Ic are Protective current input, and I0 is zero sequence current input. Terminal X3 is the ac voltage input connection, U1, U2, U3 are three-phase voltage access, U4 is external zero sequence voltage access. The ac circuit generally adopts the three-phase four-wire system, and the three-phase three-wire system can be connected according to figure 5.2.

选择不同的接线方式，需修改装置“定值”菜单的“定值修改”子菜单里的“电压接线方式”设置：2PT——三相三线制；3PT——三相四线制。

The setting “PT Mode” will be changed corresponding to the ac voltage connection. For example, “PT Mode” is set as "2PT" while the three-phase three-wire system and “PT Mode” is set as "3PT" in the three-phase four-wire system.

X5 为标配的开入接线端子，共有 12 路输入，分为 3 组，每组有一公共端。第一组有 DI1 和 DI2，第二组有 DI3 –DI8，第三组有 DI9 –DI12，同组的开入必须有相同的极性。

X5 is the standard open terminal, with a total of 12 digital input which are divided into 3 groups, each with a common port. DI1 and DI2 in the first group, DI3-DI8 in the second group, DI9-DI12 in the third group, and the same polarity in the same group.

电流型保护装置 AM4-I 的开入量配置可按开关柜类型进行设置。在“定值修改”菜单中的“开关柜类型”，可分别设置为默认、进出线、变压器三种模式，其对应的开入量配置如下表：

Current type protection device AM4-I can be set according to the type of switch cabinet. The “Terminal Mode” in the “value modify” menu can be set as default, incoming line and transformer mode respectively, and the corresponding opening amount is configured as follows:

“开关柜类型” ==默认 “Switch cabinet type” == Default	“开关柜类型” ==进出线 “Switch cabinet type” == Incoming line	“开关柜类型” ==变压器 “Switch cabinet type” == “Transformer”
断路器合位 CCB On	断路器合位 CCB On	合位 CCB On
断路器分位 CCB Off	断路器分位 CCB Off	分位 CCB Off
工作位置 Working Position	工作位置 Working Position	重瓦斯 Heavy Gas
试验位置 Testing Position	试验位置 Testing Position	轻瓦斯 Light Gas
接地刀闸 Grouding Switch	弹簧未储能 Discharge	弹簧未储能 Discharge
超温跳闸 Over Temperation trip	PT 手车工作位 PT Hand Working Position	超温 High Temp
变压器门开 Door open trip	接地刀闸 Grouding Switch	变压器门开 Door open
高温告警 High Temperation alarm	远方指示 Remote	高温告警 Over Temp
远方指示 Remote	手动分闸 Manual trip	远方指示 Remote
弹簧未储能 Discharge	手动合闸 Manual Close	接地刀闸 Grouding Switch
非电量 1 Non-electric 1	备用 1 Spare 1	工作位置 Working Position
非电量 2 Non-electric 1	备用 2 Spare 2	试验位置 Testing Position

X6 为标配的开出接线端子，共有 5 路电磁式继电器无极性接点，均为常开触点。

X6 is the standard wiring terminal of digital output, and there are no polarity contact points of the five electromagnetic relays, all of which are normally open contacts.

X2 为通信端子，有 1 路 RS485 通信端子，通讯支持 IEC60870-5-103 和 Modbus RTU 通讯规约且可任意配置。

X2 is the communication terminal. There is one RS485 communication terminal, and the

communication supports IEC60870-5-103 and Modbus RTU communication protocol and can be configured arbitrarily.

X4 为辅助电源端子，交直流均可接入，X4.3 为辅助电源保护地，必须可靠连接大地。

X4 is the auxiliary power terminal, which can be connected to the dc or ac. X4.3 is the auxiliary power protection ground and must be reliably connected to the earth.

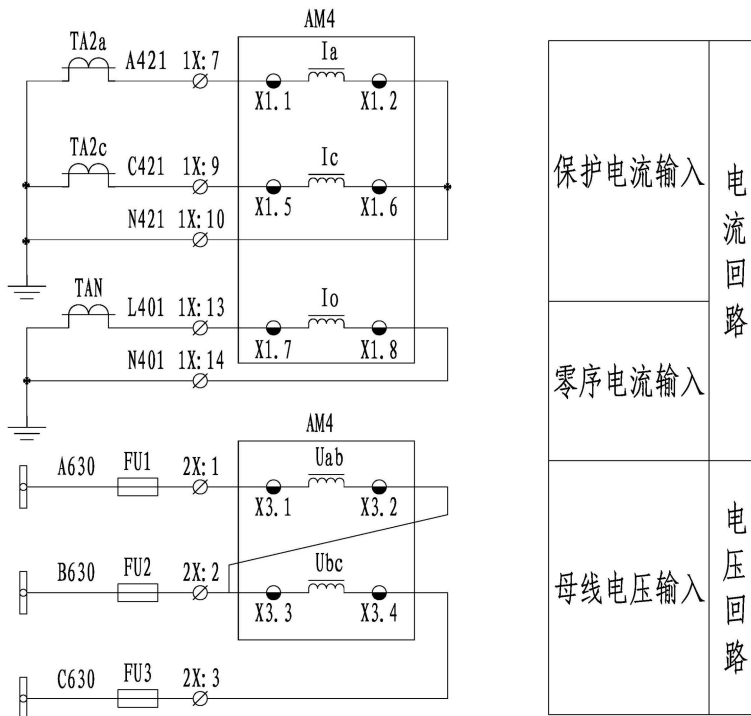


图 5.2 2PT 2CT 接线方法

Figure 5.2 2PT 2CT Wiring method

第六章 维护及其他问题处理

Chapter 6 Maintenance and other issues

AM4 微机保护装置为免维护产品，只要安装运行环境满足要求，正常运行期间不需要日常及定期保养维护。但要留意因长期轻微震动引起的螺丝松动情况。

AM4 microcomputer protection device is Maintenance free products. As long as the installation operation environment meets the requirements, normal operation period does not require daily and regular maintenance. However, be aware of the screw loose caused by a long period of slight vibration.

下表是在装置使用过程中可能会遇到的问题及相应处理建议。

The following table is the possible problems encountered during the use of the device and corresponding processing suggestions.

问题 Problems	可能原因 Possible causes	处理建议 Processing suggestions
继电器不跳闸 The DO without trip	该功能投退未投入； 条件闭锁 The Enale is exit; Conditions for closure	在定值表里投入相应保护投退； 检查是否有闭锁条件满足 Set the corresponding protection enable on; Check if there is a closed condition.
装置背面的 RS485 口无通讯 No communication	接线极性接反； 通讯参数或规约不一致 Connection polarity reversal; Communication parameters or specifications are inconsistent;	调换接线极性； 重新设置通讯参数或规约 Reversal polarity; Check the communication parameters or specifications.

附录 A 装置出厂默认定值表

Accessories A Setting value

AM4-I (电流型保护装置) 定值表 AM4-I (Current type protection device) Setting value				
保护名称 Protection Function	定值名称 Value name	默认值 Default	范围 Range	备注 Notice
	开关柜类型 TerminalMode	2	2~2	默认;进出线;变压器 Default; Line; Transformer
	进线 PT 选择 Incoming PT	0	0~1	不带; 带 No; Yes
	CT 变比 CT	10	0.1~9999	
	PT 变比 PT	100	0.1~9999	
	电压接线方式 PT Mode	0	0~1	3PT; 2PT
	电流接线方式 CT Mode	0	0~1	3CT; 2CT
	跳闸展宽 Tripping pulse	0.15s	0~1	
	默认延时 Default delay	0.01s	0~0.04	
	低压阈值 U.Less	15V	1~200	低电压判据 Under Voltage criterion
	相间低电压定值 U.Under	70V	1~200	
	复合电压负序定值 U2	35V	1~200	
过流一段 3I>>>	过流一段投退 E.3I>>>	0	0~1	退出; 投入 OFF; ON
	一段经低压 E.3I>>>.U	0	0~1	退出; 投入 OFF; ON
	过流一段定值 3I>>>	10A	0.04~75	

	过流一段延时 3I>>>.T	0s	0~60	
过流二段 3I>>	过流二段投退 E.3I>>	0	0~1	退出；投入 OFF; ON
	二段经低压 E.3I>>.U	0	0~1	退出；投入 OFF; ON
	过流二段定值 3I>>	7.5A	0.04~75	
	过流二段延时 3I>>.T	0.2s	0~60	
过流三段 3I>	过流三段投退 E.3I>	0	0~1	退出；投入 OFF; ON
	过流三段方式 E.3I>.M	0	0~1	告警；跳闸 Alarm; Trip
	三段经低压 E.3I>.U	0	0~1	退出；投入 OFF; ON
	过流三段定值 3I>	7A	0.04~75	
	过流三段延时 3I>.T	0.5s	0~60	
反时限过流 Inver.Time I>	反时限过流投退 E.I>.Inv	0	0~1	退出；投入 OFF; ON
	反时限经低压 E.I>.Inv.U	0	0~1	退出；投入 OFF; ON
	反时限启动电流 I>.Inv	6A	0.04~75	
	反时限时间系数 I>.Inv.K	0.1s	0~100	
	反时限曲线类型 I>.Inv.X	0	0~2	一般；非常；极端 S1;S2;S3
过负荷告警 Overload	过负荷投退 E.I>Lo	0	0~1	退出；投入 OFF; ON
	过负荷方式 E.I>Lo.M	0	0~1	告警；跳闸 Alarm; Trip
	过负荷定值 I>Lo	6.5A	0.04~75	

	过负荷延时 I>Lo.T	1s	0~999	
I0 过流一段 I0>>	I0 过流一段投退 E.I0>>	0	0~1	退出; 投入 OFF; ON
	I0 一段定值 I0>>	3A	0.04~75	
	I0 一段延时 I0>>.T	5s	0~60	
I0 过流二段 I0>	I0 过流二段投退 E.I0>	0	0~1	退出; 投入 OFF; ON
	I0 二段方式 E.I0>.M	0	0~1	告警; 跳闸 Alarm; Trip
	I0 二段定值 I0>	2A	0.04~75	
	I0 二段延时 I0>.T	10s	0~60	
I0 反时限过流 Inver.Time I0>	I0 反时限投退 E.I0.Inv	0	0~1	退出; 投入 OFF; ON
	I0 反时限启动值 I0. Inv	6A	0.04~75	
	I0 反时限系数 I0.Inv.K	0.1s	0~100	
	I0 反时限曲线 I0.Inv.X	0	0~2	一般; 非常; 极端 S1;S2;S3
低电压保护 Under.Vol.T	低电压保护投退 E.LVP	0	0~1	退出; 投入 OFF; ON
	低电压方式 E.LVPM	0	0~1	告警; 保护 Alarm; Trip
	低电压保护定值 U.LVP	50V	1~200	
	低电压保护延时 LVPT	5s	0~60	
	无流闭锁投退 E.LVPI.B	0	0~1	退出; 投入 OFF; ON
	无流定值 I.None	0.2A	0.04~75	

过电压保护 Over.Vol.T	过电压保护投退 E.OVP	0	0~1	退出；投入 OFF; ON
	过电压方式 E.OVP.M	0	0~1	告警；保护 Alarm; Trip
	过电压保护定值 U.OVP	110V	1~200	
	过电压保护延时 OVP.T	10s	0~999	
零序过压告警 Over.U0.Al	零序过压投退 E.U0.OVP	0	0~1	退出；投入 OFF; ON
	零序过压方式 E.U0.OVP.M	0	0~1	告警；保护 Alarm; Trip
	零序过压定值 U0.OVP	110V	1~200	
	零序过压延时 U0.OVP.T	10s	0~999	
控故障告警 CtrErrorAla.	控故障告警投退 E.CB.A	0	0~1	退出；投入 OFF; ON
	控故障告警延时 CB.A.T	10s	0~999	
PT 断线告警 PT BreakAla.	PT 断线告警投退 E.PtBr.A	0	0~1	退出；投入 OFF; ON
	无压定值 U.None	15V	1~200	
	PT 断线负序电压 U2.Pt	35V	1~200	
	PT 断线告警延时 PtBr.T	3s	0~999	
超温跳闸 Over Temperation	超温跳闸投退 E.HTem.T	0	0~1	退出；投入 OFF; ON
	超温跳闸延时 HTem.T	5s	0~60	
门开保护 Door Open	门开投退 E.DoOp.	0	0~1	退出；投入 OFF; ON
	门开方式 E.DoOp.M	0	0~1	告警；跳闸 Alarm; Trip

	门开延时 DoOp.T	5s	0~999	
高温告警 High Temperation	高温告警投退 E.OTem.A	0	0~1	退出；投入 OFF; ON
	高温告警延时 OTem.T	5s	0~999	
重瓦斯跳闸 HeavyGas Trip	重瓦斯跳闸投退 E.SGas.T	0	0~1	退出；投入 OFF; ON
	重瓦斯跳闸延时 SGas.T	5s	0~60	
轻瓦斯告警 LightGas Alarm	轻瓦斯告警投退 E.LGas.A	0	0~1	退出；投入 OFF; ON
	轻瓦斯告警延时 LGas.T	5s	0~999	
重合闸 Reclose	重合闸投退 E.Reclos	0	0~1	退出；投入 OFF; ON
	重合充电延时 Rec.C.T	15s	0~60	
	重合闸延时 Reclose.T	5s	0~60	
	保护重合返回延时 T.R.T	30s	0~999	
	重合闸方式 Reclose.X	0	0~1	不检；检无压 No Check; Check
	不对应重合投退 E.nonP.	0	0~1	退出；投入 OFF; ON
后加速过流 Post Accelerating I>	后加速过流投退 E.I>P	0	0~1	退出；投入 OFF; ON
	后加速经低压 E.I>P.U	0	0~1	退出；投入 OFF; ON
	后加速过流定值 I>P	6.5A	0.04~75	
	后加速过流延时 I>P.T	0s	0~60	
I0 后加速过流 Post Accelerating	I0 后加速过流投退 E.I0>P	0	0~1	退出；投入 OFF; ON

I0>	I0 后加速方式 E.I0>P.M	0	0~1	告警；跳闸 Alarm; Trip
	I0 后加速过流定值 I0>P	1A	0.04~75	
	I0 后加速过流延时 I0>P.T	0s	0~60	
低频减载 Under Frequency	低频减载投退 E.UnderFr.	0	0~1	退出；投入 OFF; ON
	低压闭锁 E.UnderFr.U	0	0~1	退出；投入 OFF; ON
	欠流闭锁 E.UnderFr.I	0	0~1	退出；投入 OFF; ON
	滑差闭锁 E.UnderFr.dHz.	0	0~1	退出；投入 OFF; ON
	低频减载定值 UnderFr.	49Hz	45~60	
	低频减载延时 UnderFr.T	5s	0~60	
	滑差闭锁值 dHz.B	0.1	0.01~100	
	欠流闭锁值 I.B	5A	0.2~75	
	低压闭锁值 U.B	50V	0~200	
非电量 1 保护 Non-electric 1	非电量 1 投退 E.Non-el1	0	0~1	退出；投入 OFF; ON
	非电量 1 方式 E.Non-el1.M	0	0~1	告警；跳闸 Alarm; Trip
	非电量 1 延时 Non-el1.T	5s	0~999	
非电量 2 保护 Non-electric 2	非电量 2 投退 E.Non-el2	0	0~1	退出；投入 OFF; ON
	非电量 2 方式 E.Non-el2.M	0	0~1	告警；跳闸 Alarm; Trip
	非电量 2 延时 Non-el2.T	5s	0~999	

负序过流一段 I2>>.T	负序过流一段投退 E.I2>>	0	0~1	退出；投入 OFF; ON
	负序过流一段定值 I2>>	10A	0.04~75	
	负序过流一段延时 I2>>.T	5s	0~60	
负序过流二段 I2>.A	负序过流二段投退 E.I2>	0	0~1	退出；投入 OFF; ON
	负序二段方式 E.I2>.M	0	0~1	告警；跳闸 Alarm; Trip
	负序过流二段定值 I2>	9A	0.04~75	
	负序过流二段延时 I2>.M	10s	0~999	
负序反时限过流 I2.Inv.Tr	负序反时限投退 E.I2>Inv	0	0~1	退出；投入 OFF; ON
	负序反时限电流 I2>Inv	6A	0.04~75	
	负序反时限系数 I2>Inv.K	0.1s	0~100	
	负序反时限曲线 I2>Inv.X	0	0~2	一般；非常；极端 S1;S2;S3
FC 配合的过流闭锁功能 FC Block	FC 闭锁投退 E.FCBlock	0	0~1	退出；投入 OFF; ON
	FC 闭锁电流定值 FCB.I	10A	0.04~75	
	FC 闭锁延时 FCB.T	5s	0~60	
二次谐波闭锁 Second Harmonic Block	二次谐波闭锁投退 E.SHB.	0	0~1	退出；投入 OFF; ON
	二次谐波闭锁定值 SHB.I	15%	0~100	

AM4-U1 定值表 AM4-U1 Setting value				
保护名称 Protection Function	定值名称 Value name	默认值 Default	范围 Range	备注 Notice
	开关柜类型 TerminalMode	1	0~2	默认;PT柜;其它 Default; PT; Other
	PT变比 PT	100	0.1~9999	
	电压接线方式 PT Mode	0	0~1	3PT; 2PT
低电压告警 Under.Vol.A	低电压告警投退 E.U.Un.A	0	0~1	退出; 投入 OFF;ON
	低电压告警定值 U.Un.A	50V	1~200	
	低电压告警延时 U.Un.A.T	5s	0~999	
过电压告警 OVP.A	过电压告警投退 E.OVP.A	0	0~1	退出; 投入 OFF;ON
	过电压告警定值 OVP.A	110V	1~200	
	过电压告警延时 OVP.A.T	10s	0~999	
零序过压告警 Over.U0.A1	零序过压告警投退 E.O.U0	0	0~1	退出; 投入 OFF;ON
	零序过压告警定值 O.U0	110V	1~200	
	零序过压告警延时 O.U0.T	10s	0~999	
3U0告警 Over 3U0.A	3U0告警投退 E.O.3U0.A	0	0~1	退出; 投入 OFF;ON
	3U0告警定值 O.3U0.A	110V	1~200	
	3U0告警延时 O.3U0.A.T	10s	0~999	
PT断线告警 PT BreakAla.	PT断线告警投退 E.PtBr.A	0	0~1	退出; 投入 OFF;ON

	PT 断线负序电压 U2.Pt	35V	1~200	
	PT 断线告警延时 PtBr.T	3s	0~999	

附录 B 装置事件记录清单

Accessories B SOE List

AM 事件记录 AM Event Record				
事件代码 Event code	事件名称 Event name	参数名称 Parameter name	参数值 Parameter values	参数单位 Parameter unit
0	过流一段保护 3I>>>	A 相电流 Ia	浮点数 Float	A
		B 相电流 Ib	浮点数 Float	A
		C 相电流 Ic	浮点数 Float	A
		UAB	浮点数 Float	V
		UBC	浮点数 Float	V
		UCA	浮点数 Float	V
		负序电压 U2	浮点数 Float	V
		A 相二次谐波电流 Ia_H2	浮点数 Float	A
		B 相二次谐波电流 Ib_H2	浮点数 Float	A
		C 相二次谐波电流 Ic_H2	浮点数 Float	A
1	过流二段保护 3I>>	A 相电流 Ia	浮点数 Float	A
		B 相电流 Ib	浮点数 Float	A
		C 相电流 Ic	浮点数 Float	A
		UAB	浮点数 Float	V
		UBC	浮点数 Float	V
		UCA	浮点数 Float	V
		负序电压 U2	浮点数 Float	V
		A 相二次谐波电流	浮点数	A

		Ia_H2	Float	
		B相二次谐波电流 Ib_H2	浮点数 Float	A
		C相二次谐波电流 Ic_H2	浮点数 Float	A
2	过流三段保护 3I>	A相电流 Ia	浮点数 Float	A
		B相电流 Ib	浮点数 Float	A
		C相电流 Ic	浮点数 Float	A
		UAB	浮点数 Float	V
		UBC	浮点数 Float	V
		UCA	浮点数 Float	V
		负序电压 U2	浮点数 Float	V
		A相二次谐波电流 Ia_H2	浮点数 Float	A
		B相二次谐波电流 Ib_H2	浮点数 Float	A
		C相二次谐波电流 Ic_H2	浮点数 Float	A
3	启动时过流一段保护 3I>>>.S	A相电流 Ia	浮点数 Float	A
		B相电流 Ib	浮点数 Float	A
		C相电流 Ic	浮点数 Float	A
4	运行时过流一段保护 3I>>>.R	A相电流 Ia	浮点数 Float	A
		B相电流 Ib	浮点数 Float	A
		C相电流 Ic	浮点数 Float	A
5	A相反时限过流保护 Ia>InverseT.	时间 t	浮点数	s
		A相电流 Ia	浮点数 Float	A
		B相电流 Ib	浮点数 Float	A

		C 相电流 Ic	浮点数 Float	A
		UAB	浮点数 Float	V
		UBC	浮点数 Float	V
		UCA	浮点数 Float	V
		负序电压 U2	浮点数 Float	V
6	B 相反时限过流保护 Ib>InverseT.	时间 t	浮点数	s
		A 相电流 Ia	浮点数 Float	A
		B 相电流 Ib	浮点数 Float	A
		C 相电流 Ic	浮点数 Float	A
		UAB	浮点数 Float	V
		UBC	浮点数 Float	V
		UCA	浮点数 Float	V
		负序电压 U2	浮点数 Float	V
7	C 相反时限过流保护 Ic>InverseT.	时间 t	浮点数	s
		A 相电流 Ia	浮点数 Float	A
		B 相电流 Ib	浮点数 Float	A
		C 相电流 Ic	浮点数 Float	A
		UAB	浮点数 Float	V
		UBC	浮点数 Float	V
		UCA	浮点数 Float	V
		负序电压 U2	浮点数 Float	V
8	I01 过流一段	I01	浮点数	A

	I01>>>>		Float	
9	I01 过流二段 I01>>	I01	浮点数 Float	A
10	I02 过流一段 I02>>>>	I02	浮点数 Float	A
11	I02 过流二段 I02>>	I02	浮点数 Float	A
12	I01 反时限 I01>InverseT.	时间 t	浮点数 Float	s
		I01	浮点数 Float	A
13	I02 反时限 I02>InverseT.	时间 t	浮点数 Float	s
		I02	浮点数 Float	A
14	后加速过流保护 I>P.T	A 相电流 Ia	浮点数 Float	A
		B 相电流 Ib	浮点数 Float	A
		C 相电流 Ic	浮点数 Float	A
15	重合闸 Reclose	——	——	——
16	低频减载 UnderFr.	频率 Frequency	浮点数 Float	Hz
17	手动合闸 ManualClose	——	——	——
18	手动分闸 ManualTrip	——	——	——
19	过负荷跳闸 OverLoadTrip	最大相电流 Im	浮点数 Float	A
20	负序过流一段保护 I2>>>>	负序电流 I2	浮点数 Float	A
		最大相电流 Im	浮点数 Float	A
21	负序反时限保护 I2>InverseT	时间 t	浮点数 Float	s
		负序电流 I2	浮点数 Float	A
22	热过载跳闸 OverHeat.T	跳闸百分比 Trip Percent	浮点数 Float	%
		最大相电流 Im	浮点数 Float	A

		正序电流 I1	浮点数 Float	A
		负序电流 I2	浮点数 Float	A
23	堵转保护 StallTrip	最大相电流 Im	浮点数 Float	A
24	启动时间过长保护 StartOutTime	最大相电流 Im	浮点数 Float	A
25	低电压保护 LVP.T	最大线电压 Um	浮点数 Float	V
26	欠电压保护 LVP.T	UAB	浮点数 Float	V
		UBC	浮点数 Float	V
		UCA	浮点数 Float	V
27	过电压保护 OVP.T	UAB	浮点数 Float	V
		UBC	浮点数 Float	V
		UCA	浮点数 Float	V
28	零序过电压保护/自产零序过 压保护 U0.OVP/3U0.OVP	零序电压 U0	浮点数 Float	V
29	不平衡电压保护 Unb.V.T	不平衡 U Unb.V	浮点数 Float	V
30	不平衡电流保护 Unb.I.T	不平衡 I Unb.I	浮点数 Float	A
31	重瓦斯跳闸 SevereGas.T	——	——	——
32	压力释放跳闸 Pre.Re.T	——	——	——
33	超温跳闸 HighTemp.T	——	——	——
34	非电量 1 跳闸/计量门 1 跳闸 Non-el1.T/Me.do1.T	——	——	——
35	非电量 2 跳闸/计量门 2 跳闸 Non-el2.T/Me.do2.T	——	——	——
36	分段备投合母联 B.S.C.B.	——	——	——
37	分段备投跳进线 1 B.S.T.1	——	——	——

38	分段备投跳进线 2 B.S.T.2	——	——	——
39	2 备 1 跳进线 1 2S.1T.1-In.	——	——	——
40	2 备 1 合进线 2 2S.1C.2-In.	——	——	——
41	1 备 2 跳进线 2 1S.2T.2-In.	——	——	——
42	1 备 2 合进线 1 1S.2C.1-In.	——	——	——
43	分段复归合进线 1 B.R.C.1	——	——	——
44	分段复归合进线 2 B.R.C.2	——	——	——
45	分段复归跳母联 B.R.T.B.	——	——	——
46	2 备 1 复归合进线 1 2S.1R.C.1	——	——	——
47	2 备 1 复归跳进线 2 2S.1R.T.2	——	——	——
48	1 备 2 复归合进线 2 1S.2R.C.2	——	——	——
49	1 备 2 复归跳进线 1 1S.2R.T.1	——	——	——
50	FC 闭锁 FC Block	A 相电流 Ia	浮点数 Float	A
		B 相电流 Ib	浮点数 Float	A
		C 相电流 Ic	浮点数 Float	A
51	变压器门误开跳闸 DoorOpenT	——	——	——
52	遥控合闸 RemoteClose	——	——	——
53	遥控分闸 RemoteTrip	——	——	——
54	失压保护 LVPT	最大线电压 Um	浮点数 Float	V
55	油位低跳闸 Low oil.T	——	——	——
56	油位高跳闸 High oil.T	——	——	——
57	反时限过流保护	时间	浮点数	s

	I>InverseT.	t	Float	
		A 相电流 Ia	浮点数 Float	A
		B 相电流 Ib	浮点数 Float	A
		C 相电流 Ic	浮点数 Float	A
58	I01 过流三段 I01>	I01	浮点数 Float	A
59	I01 后加速过流 I01>P.T	时间 t	浮点数 Float	s
		I01	浮点数 Float	A
60	高温保护跳闸 OverTemp.T	——	——	——
61	轻瓦斯保护跳闸 LightGasT	——	——	——
62	2 备 1 跳母联 2S.1T.B.	——	——	——
63	2 备 1 复归合母联 2S.1R.C.B.	——	——	——
64	柴发机备投跳进线 1 Die.S.T.1	——	——	——
65	柴发机备投跳进线 2 Die.S.T.2	——	——	——
66	柴发机备投合母联 Die.S.C.B.	——	——	——
67	柴发机备投合柴发机 Die.S.C.D.	——	——	——
68	非电量 3 跳闸 Non-el3.T	——	——	——
69	非电量 4 跳闸 Non-el4.T	——	——	——
70	备用 1 跳闸 Spare1.T	——	——	——
71	备用 2 跳闸 Spare2.T	——	——	——
73	备用 3 跳闸 Spare3.T	——	——	——
74	隔离柜连跳 Iso.Cab.T	——	——	——
75	系统谐振跳闸	——	——	——

	Sys.Res.T			
76	高频保护 OF.T	频率 Frequency	浮点数 Float	Hz
77	温控器故障跳闸 Th.Fa.T	——	——	——
78	自产 3I0 保护一段跳闸 3I0>>>	A 相电流 Ia	浮点数 Float	A
		B 相电流 Ib	浮点数 Float	A
		C 相电流 Ic	浮点数 Float	A
		3I0	浮点数 Float	A
79	自产 3I0 保护二段跳闸 3I0>>	A 相电流 Ia	浮点数 Float	A
		B 相电流 Ib	浮点数 Float	A
		C 相电流 Ic	浮点数 Float	A
		3I0	浮点数 Float	A
80	过负荷告警 OverLoadAla.	最大相电流 Im	浮点数 Float	A
81	PT 断线告警 (AM5、AM4-U) PT BreakAla.	UAB	浮点数 Float	V
		UBC	浮点数 Float	V
		UCA	浮点数 Float	V
		负序电压 U2	浮点数 Float	V
82	控故障告警 CtrErrorAla.	——	——	——
83	负序过流二段告警 I2>>.A	负序电流 I2	浮点数 Float	A
		最大相电流 Im	浮点数 Float	A
84	热过载告警 OverHeat.A	告警百分比 Alarm percent	浮点数 Float	%
		最大相电流 Im	浮点数 Float	A
		正序电流 I1	浮点数 Float	A

		负序电流 I2	浮点数 Float	A
85	I母低电压告警 (AM5\AM4-U1) I Bus LVP.A	最大线电压 Um	浮点数 Float	V
86	I母过电压告警 (AM5\AM4-U1) I Bus OVP.A	最大线电压 Um	浮点数 Float	V
87	I母零序过压告警 (AM5\AM4-U1) I Bus U0.OVP.A	零序电压 U0	浮点数 Float	V
88	轻瓦斯告警 LightGasA			
89	高温告警 OverTemp.A			
90	非电量 2 告警 Non-eI2.A	——	——	——
91	非电量 3 告警 Non-eI3.A	——	——	——
92	分段充电完成 BusCharge	——	——	——
93	进线 1 充电完成 I-In.Charge	——	——	——
94	进线 2 充电完成 2-In.Charge	——	——	——
95	I母自产零序过压告警 (AM5\AM4-U1) I Bus 3U0.OVP.A	零序电压 U0	浮点数 Float	V
96	II母低电压告警 (AM5\AM4-U2) II Bus LVP.A	最大线电压 Um	浮点数 Float	V
97	II母零序过压告警 (AM5\AM4-U2) II Bus U0.OVP.A	零序电压 U0	浮点数 Float	V
98	II母 PT 断线告警 (AM5\AM4-U2) II Bus PT BreakAla.	UAB2	浮点数 Float	V
		UBC2	浮点数 Float	V
		UCA2	浮点数 Float	V
		负序电压 U2	浮点数 Float	V
99	II母过电压告警	最大线电压	浮点数	V

	(AM5\AM4-U2) II Bus OVP.A	Um	Float	
100	II母自产零序过压告警 (AM5\AM4-U2) II Bus 3U0.OVP.A	自产 3U0 3U0	浮点数 Float	V
101	电机备投跳进线 1,2 M.S.T.1,2	——	——	——
102	电机备投合电机 M.S.C.M.	——	——	——
103	过流三段告警 3I>.A	A 相电流 Ia	浮点数 Float	A
		B 相电流 Ib	浮点数 Float	A
		C 相电流 Ic	浮点数 Float	A
104	I01 过流一段告警 I01>>>.A	时间 t	浮点数 Float	s
		I01	浮点数 Float	A
105	I01 过流二段告警 I01>>.A	时间 t	浮点数 Float	s
		I01	浮点数 Float	A
106	I01 过流三段告警 I01>.A	时间 t	浮点数 Float	s
		I01	浮点数 Float	A
107	I01 反时限过流告警 I01>InverseT.A	时间 t	浮点数 Float	s
		I01	浮点数 Float	A
108	I01 后加速告警 I01>P.A	时间 t	浮点数 Float	s
		I01	浮点数 Float	A
109	I02 过流告警 I02>.A	时间 t	浮点数 Float	s
		I02	浮点数 Float	A
110	I02 反时限过流告警 I02>InverseT.A	时间 t	浮点数 Float	s
		I02	浮点数 Float	A

111	负序过流一段告警 I2>>>.A	负序电流 I2	浮点数 Float	A
		最大相电流 Im	浮点数 Float	A
112	超温保护告警 HighTemp.A			
113	重瓦斯保护告警 SevereGas.A			
114	失压告警 LVP.A	最大线电压 Um	浮点数 Float	V
115	I02 过流一段告警 I02>>>.A	时间 t	浮点数 Float	s
		I02	浮点数 Float	A
116	I02 过流二段告警 I02>>.A	时间 t	浮点数 Float	s
		I02	浮点数 Float	A
117	门开告警 DoorOpenA	时间 t	浮点数 Float	s
118	进线 PT 断线 I.PtBr.A	——	——	——
119	非电量 1 告警 Non-el1.A			s
120	非电量 4 告警 Non-el4.A			s
121	重合闸充电完成 chargeOK	——	——	——
122	备用 1 告警 Spare1.A	——	——	——
123	备用 2 告警 Spare2.A	——	——	——
124	备用 3 告警 Spare3.A	——	——	——
125	市电充电 Mark.Charge	——	——	——
126	市电备投跳发电机 Mark.S.T.D.	——	——	——
127	市电备投合进线 1 Mark.S.C.1	——	——	——
128	市电备投合进线 2 Mark.S.C.2	——	——	——
129	逆功率保护	有功功率	浮点数	kW

	RP.T	Active power	Float	
		功率因数 Power factor	浮点数 Float	
130	压力释放告警 Pre.Re.A	—	—	—
131	发电机备 1 充电 Al.S.1.Charge	—	—	—
132	发电机备 2 充电 Al.S.2.Charge	—	—	—
133	柴发机备 1 跳 1QF Die.S.1T.1QF	—	—	—
134	柴发机备 1 合 4QF Die.S.1C.4QF	—	—	—
135	柴发机备 2 跳 2QF Die.S.2T.2QF	—	—	—
136	柴发机备 2 合 4QF Die.S.2C.4QF	—	—	—
137	温控器故障告警 Th.Fa.A	—	—	—
138	二次过压告警（非电量） Se.OVP.A	—	—	—
139	不平衡电流 3I0 保护告警 Unb.3I0.A	A 相电流 Ia	浮点数 Float	A
		B 相电流 Ib	浮点数 Float	A
		C 相电流 Ic	浮点数 Float	A
		3I0	浮点数 Float	A
150	DI1 变位 DI1	—	—	—
151	DI2 变位 DI2	—	—	—
152	DI3 变位 DI3	—	—	—
153	DI4 变位 DI4	—	—	—
154	DI5 变位 DI5	—	—	—
155	DI6 变位 DI6	—	—	—
156	DI7 变位	—	—	—

	DI7			
157	DI8 变位 DI8	—	—	—
158	DI9 变位 DI9	—	—	—
159	DI10 变位 DI10	—	—	—
160	DI11 变位 DI11	—	—	—
161	DI12 变位 DI12	—	—	—
162	DI13 变位 DI13	—	—	—
163	DI14 变位 DI14	—	—	—
164	DI15 变位 DI15	—	—	—
165	DI16 变位 DI16	—	—	—
166	DI17 变位 DI17	—	—	—
167	DI18 变位 DI18	—	—	—
168	DI19 变位 DI19	—	—	—
169	DI20 变位 DI20	—	—	—
170	合后位置变位 Position after closing set	—	—	—
171	合位监视变位 CCB On set	—	—	—
172	分位监视变位 CCB Off set	—	—	—
173	防跳监视变位 Anti-pumping set	—	—	—
174	装置上电 Device on power	—	—	—
179	PT 断线 PT Break	—	—	—
180	3 备 1 充电 3S.1 Charge	—	—	—
181	3 备 2 充电	—	—	—

	3S.2 Charge			
182	A 相差压跳闸 UdA.T	A 相差压 UdA	浮点数 Float	V
183	B 相差压跳闸 UdB.T	B 相差压 UdB	浮点数 Float	V
184	C 相差压跳闸 UdC.T	C 相差压 UdC	浮点数 Float	V
185	备投再恢复 1#合 3QF S.R.1#.C.3QF	——	——	——
186	均无压恢复充电 No-Vol.R.Charge	——	——	——
187	均无压复 2 跳 4 No-Vol.R.2.T.4	——	——	——
188	均无压复 2 合 2 No-Vol.R.2.C.2	——	——	——
189	均无压复 1 跳 4 No-Vol.R.1.T.4	——	——	——
190	均无压复 1 合 1 No-Vol.R.1.C.1	——	——	——
191	均无压复 1 合 3 No-Vol.R.1.C.3	——	——	——
192	远方按钮合闸 Remote button close	——	——	——
193	远方按钮分闸 Remote button trip	——	——	——
194	急停分闸 Emergency trip	——	——	——
195	2 备 1 合柴发 2S.1C.Die.	——	——	——
196	2 备 1 复归跳柴发 2S.1R.T.Die.	——	——	——
197	负控跳闸 Neg.Con.T	——	——	——
198	绝缘监测告警 Insul.Monit.A	——	——	——
199	绝缘监测跳闸 Insul.Monit.T	——	——	——
200	均无压充电 No-Vol.Charge	——	——	——
201	均无压跳 2 No-Vol.T.2	——	——	——
202	均无压合 1 No-Vol.C.1	——	——	——

203	备用进线备 1 充电 Sp.In.S1 Charge	——	——	——
204	备用进线备 2 充电 Sp.In.S2 Charge	——	——	——
205	备用进线备 1 跳进线 1 Sp.In.S1.T.1	——	——	——
206	备用进线备 1 合备用 Sp.In.S1.C.Sp.	——	——	——
207	备用进线备 2 跳进线 2 Sp.In.S2.T.2	——	——	——
208	备用进线备 2 合备用 Sp.In.S2.C.Sp	——	——	——
209	均无压跳进线 1,2 No-Vol.T.1,2	——	——	——
210	均无压合母联 No-Vol.C.B.	——	——	——
211	均无压合备用进线 No-Vol.C.Sp.In.	——	——	——
212	欠流告警 LIP.A	A 相电流 Ia	浮点数 Float	A
		B 相电流 Ib	浮点数 Float	A
		C 相电流 Ic	浮点数 Float	A
213	电压不平衡开入跳闸 Unb.V.DI.T	——	——	——
214	分段备投合进线 3 B.S.C.3	——	——	——
215	分段备投合进线 4 B.S.C.4	——	——	——
216	进线 1 逆功率 1-In.RP.T	——	——	——
217	2 备 1 退进线 1 手车 2S.1T.1-In.Hand.	——	——	——
218	2 备 1 复归合进线 1 手车 2S.1R.C.1-In.Hand.	——	——	——
219	低侧网门告警 Low S.D.A	——	——	——
220	低侧网门跳闸 Low S.D.T	——	——	——
221	事故总信号 Accident Signal	——	——	——
222	电压不平衡跳闸	——	——	——

	Unb.V.T			
223	相序保护跳闸 Ph.Se.T	—	—	—
224	断相保护跳闸 Break ph.T	—	—	—
225	I段 PT 投入 I PT Invest.	—	—	—
226	II段 PT 投入 II PT Invest.	—	—	—
227	PT 并列 PT Juxtaposition	—	—	—
228	1 号 2 号主供断电警报 1,2 Main supply outage.A	—	—	—
229	遥控并列 Remote Juxtaposition	—	—	—
230	遥控解列 Remote Splitting	—	—	—
231	母线充电保护 B.Cha.T	A 相电流 Ia	浮点数 Float	A
		B 相电流 Ib	浮点数 Float	A
		C 相电流 Ic	浮点数 Float	A
232	CT 二次过压跳闸 CT Se.OVP.T	—	—	—
233	CT 二次过压告警 CT Se.OVP.A	—	—	—
234	隔离手车连跳动作 Iso.Handcart.T	—	—	—
235	备投允许 Standby allowed	—	—	—
236	允许合闸信号 Allowable C.signal	—	—	—
237	柴发机备投跳母联 Die.S.T.B.			
238	备投启动柴发信号 S.Sta.Die.Sig.			
239	油位高告警 High oil.A			
240	均无压跳母联 No-Vol.T.B.			
241	负序过流二段跳闸 I2>>	负序电流 I2	浮点数 Float	A

		最大相电流 Im	浮点数 Float	A
242	差动总启动标志 Differential total start flag	——	——	——
243	差动速断保护 Differential quick break protection	动作时间 Action time	浮点数 Float	s
		A 相差流 IdA	浮点数 Float	A
		B 相差流 IdB	浮点数 Float	A
		C 相差流 IdC	浮点数 Float	A
		A 相制动 IrA	浮点数 Float	A
		B 相制动 IrB	浮点数 Float	A
		C 相制动 IrC	浮点数 Float	A
244	比率差动保护 Ratio differential protection	动作时间 Action time	浮点数 Float	s
		A 相差流 IdA	浮点数 Float	A
		B 相差流 IdB	浮点数 Float	A
		C 相差流 IdC	浮点数 Float	A
		A 相制动 IrA	浮点数 Float	A
		B 相制动 IrB	浮点数 Float	A
		C 相制动 IrC	浮点数 Float	A
245	差流越限 Differential current overshoot	A 相差流 IdA	浮点数 Float	A
		B 相差流 IdB	浮点数 Float	A
		C 相差流 IdC	浮点数 Float	A
246	正序过流一段保护 II>>>	定值 Fixed value	浮点数 Float	A
		延时 Delayed	浮点数 Float	s
		正序电流	浮点数	A

		I1	Float	
247	正序过流二段保护 I1>>	定值 Fixed value	浮点数 Float	A
		延时 Delayed	浮点数 Float	s
		正序电流 I1	浮点数 Float	A
248	正序过流反时限保护 I1>InverseT.	曲线类型 Curve type	整数 Integer	一般/非常/ 极端 S1/S2/S3
		启动电流 Starting current	浮点数 Float	A
		时间系数 Time coefficient	浮点数 Float	s
		动作时间 Action time	浮点数 Float	s
		正序电流 I1	浮点数 Float	A
249	长启动保护告警 Long start protection alarm	计时门槛 Timing threshold	浮点数 Float	A
		动作时间 Action time	浮点数 Float	s
250	电流不平衡告警 Unb.I.A	定值 Fixed value	浮点数 Float	A
		延时 Delayed	浮点数 Float	s
		动作值 Action value	浮点数 Float	A
		平均电流 Iavg	浮点数 Float	A
251	电压不平衡告警 Unb.V.A	定值 Fixed value	浮点数 Float	V
		延时 Delayed	浮点数 Float	s
		动作值 Action value	浮点数 Float	V
		平均线电压 Uavg	浮点数 Float	V
		UAB	浮点数 Float	V
		UBC	浮点数 Float	V
		UCA	浮点数 Float	V

			Float	
252	过电压保护告警 OVPA	定值 Fixed value	浮点数 Float	V
		延时 Delayed	浮点数 Float	s
		UAB	浮点数 Float	V
		UBC	浮点数 Float	V
		UCA	浮点数 Float	V
		零序电压 U0	浮点数 Float	V
253	零序过压保护告警 U0.OVPA	定值 Fixed value	浮点数 Float	V
		延时 Delayed	浮点数 Float	s
		UAB	浮点数 Float	V
		UBC	浮点数 Float	V
		UCA	浮点数 Float	V
		零序电压 U0	浮点数 Float	V
254	正序过压保护告警 U1.OVPA	定值 Fixed value	浮点数 Float	V
		延时 Delayed	浮点数 Float	s
		UAB	浮点数 Float	V
		UBC	浮点数 Float	V
		UCA	浮点数 Float	V
		正序电压 U1	浮点数 Float	V
255	正序过压保护跳闸 U1.OVPT	定值 Fixed value	浮点数 Float	V
		延时 Delayed	浮点数 Float	s
		UAB	浮点数 Float	V

		UBC	浮点数 Float	V
		UCA	浮点数 Float	V
		正序电压 U1	浮点数 Float	V
256	负序过压保护告警 U2.OVP.A	定值 Fixed value	浮点数 Float	V
		延时 Delayed	浮点数 Float	s
		UAB	浮点数 Float	V
		UBC	浮点数 Float	V
		UCA	浮点数 Float	V
		负序电压 U2	浮点数 Float	V
257	负序过压保护跳闸 U2.OVP.T	定值 Fixed value	浮点数 Float	V
		延时 Delayed	浮点数 Float	s
		UAB	浮点数 Float	V
		UBC	浮点数 Float	V
		UCA	浮点数 Float	V
		负序电压 U2	浮点数 Float	V
258	低电压保护告警 LVP.A	定值 Fixed value	浮点数 Float	V
		延时 Delayed	浮点数 Float	s
		UAB	浮点数 Float	V
		UBC	浮点数 Float	V
		UCA	浮点数 Float	V
		零序电压 U0	浮点数 Float	V
259	相序保护告警	延时	浮点数	s

	Ph.Se.A	Delayed	Float	
		UAB	浮点数 Float	V
		UBC	浮点数 Float	V
		UCA	浮点数 Float	V
		零序电压 U0	浮点数 Float	V
		正序电压 U1	浮点数 Float	V
		负序电压 U2	浮点数 Float	V
		平均线电压 Uavg	浮点数 Float	V
260	首端 CT 断线告警 F.CT Break.A	——	——	——
261	尾端 CT 断线告警 T.CT Break.A	——	——	——
262	I02 后加速过流 I02>P.T	时间 t	浮点数 Float	s
		I02	浮点数 Float	A
263	I02 后加速告警 I02>P.A	时间 t	浮点数 Float	s
		I02	浮点数 Float	A
264	差动保护长期启动 Long term start of differential protection	A 相差流 IdA	浮点数 Float	A
		B 相差流 IdB	浮点数 Float	A
		C 相差流 IdC	浮点数 Float	A
265				
266				
267	I侧 CT 断线告警 I CT Break.A	——	——	——
268	II侧 CT 断线告警 II CT Break.A	——	——	——

269	III侧 CT 断线告警 III CT Break.A	——	——	——
270	IV侧 CT 断线告警 IV CT Break.A	——	——	——
271	有压有流出口动作 Pressure and current outlet action	——	——	——
272	预留			
	(告警事件代码)			
289	Reserve			
290	启动风冷 Starting air cooling	A 相电流 Ia	浮点数 Float	A
		B 相电流 Ib	浮点数 Float	A
		C 相电流 Ic	浮点数 Float	A
291	闭锁调压 Blocking voltage regulation	A 相电流 Ia	浮点数 Float	A
		B 相电流 Ib	浮点数 Float	A
		C 相电流 Ic	浮点数 Float	A
292	间隙零序过流一段跳闸 Clearance I0>>>	间隙零序电流 Clearance I0	浮点数 Float	A
293	间隙零序过流二段跳闸 Clearance I0>>	间隙零序电流 Clearance I0	浮点数 Float	A
294	I段 PT 投入 I PT Invest.	——	——	——
295	II段 PT 投入 II PT Invest.	——	——	——
296	PT 自动并列 PT Juxtaposition	——	——	——
297	遥控并列 Remote Juxtaposition	——	——	——
298	遥控解列 Remote Splitting	——	——	——
299	负控保护跳闸 Neg.Con.T	时间 t	浮点数 Float	s
300	负控保护告警 Neg.Con.A	时间 t	浮点数 Float	s
301	PT 自动解列 PT Splitting	——	——	——
302	二次谐波闭锁	A 相二次谐波电流	浮点数	A

	SHB.	Ia_H2	Float	
		B 相二次谐波电流 Ib_H2	浮点数 Float	A
		C 相二次谐波电流 Ic_H2	浮点数 Float	A
303	1 备 2 跳非重要负荷 1S.2T.Unimp.Lo.	—	—	—
304	2 备 1 跳非重要负荷 2S.1T.Unimp.Lo.	—	—	—
305	I02 过流三段 I02>	I02	浮点数 Float	A
306	I02 过流三段告警 I02>.A	I02	浮点数 Float	A
307	检修状态闭锁 Maint.Sta.B.	—	—	—
308	电机温度 1 跳闸 M.Tem1.T	—	—	—
309	电机温度 1 告警 M.Tem1.A	—	—	—
310	电机温度 2 跳闸 M.Tem2.T	—	—	—
311	电机温度 2 告警 M.Tem2.A	—	—	—
312	电源监视跳闸 Pow.Monit.T	—	—	—
313	电源监视告警 Pow.Monit.A	—	—	—
314	备投停止柴发信号 S.St.Die.Sig.			
315	启动柜故障跳闸 St.Cab.Fa.T	—	—	—
316	启动柜故障告警 St.Cab.Fa.A	—	—	—
317	同期合闸 Synchronous.C	—	—	—
318	进线侧恢复充电 In.R.Charge	—	—	—
319	柴发充电 Die.Charge	—	—	—
320	市电恢复充电 Mark.R.Charge	—	—	—
321	柴发恢复充电 Die.R.Charge	—	—	—

322	柴发备投合柴发 Die.S.C.D.	——	——	——
323	市电恢复跳柴发 Mark.R.T.D.	——	——	——
324	市电恢复合市电 Mark.R.C.Mark.	——	——	——
325	柴发恢复合柴发 Mark.R.C.D.	——	——	——
326	弧光保护跳闸 Arc.Pro.T	——	——	——
327	弧光保护告警 Arc.Pro.A	——	——	——
328	均无压进线 1 充电 No-Vol.1-In.Charge	——	——	——
329	均无压进线 2 充电 No-Vol.2-In.Charge	——	——	——
330	均无压合 2 No-Vol.C.2	——	——	——
331	均无压跳 1 No-Vol.T.1	——	——	——
332	均无压跳 3 No-Vol.T.3	——	——	——
333	A 相二次谐波 A.SH.	A 相二次谐波电流 Ia_H2	浮点数 Float	A
		B 相二次谐波电流 Ib_H2	浮点数 Float	A
		C 相二次谐波电流 Ic_H2	浮点数 Float	A
334	B 相二次谐波 B.SH.	A 相二次谐波电流 Ia_H2	浮点数 Float	A
		B 相二次谐波电流 Ib_H2	浮点数 Float	A
		C 相二次谐波电流 Ic_H2	浮点数 Float	A
335	C 相二次谐波 C.SH.	A 相二次谐波电流 Ia_H2	浮点数 Float	A
		B 相二次谐波电流 Ib_H2	浮点数 Float	A
		C 相二次谐波电流 Ic_H2	浮点数 Float	A

总部：安科瑞电气股份有限公司
地址：上海市嘉定区育绿路 253 号
电话：0086-021-69158161
网址：www.acrel.cn
邮箱：acrelsh@email.acrel.cn
邮编：201801

生产基地：江苏安科瑞电器制造有限公司
地址：江苏省江阴市南闸街道东盟工业园区东盟路 5 号
电话：0086-510-86179966
网址：www.jsacrel.cn
邮箱：jyacrel001@email.acrel.cn
邮编：214405

Headquarters: Acrel Co., Ltd.

Trade Company: Acrel E-Business(Shanghai)Co., Ltd.

Address: No.253 Yulv Road, Jiading District, Shanghai, China

TEL.: 0086-21-69156352

Web-site: www.acrel-electric.com

E-mail: sales@acrel-electric.com

Postcode: 201801

Manufacturer: Jiangsu Acrel Electrical Manufacturing Co., Ltd.

Address: No.5 Dongmeng Road, Dongmeng industrial Park, Nanzha Street, Jiangyin City,
Jiangsu Province, China

TEL./Fax: 0086-510-86179970

Web-site: www.jsacrel.com

E-mail: sales@email.acrel.cn

Postcode: 214405